

INSTALLATION, OPERATION AND MAINTENANCE MANUAL

3 pieces Full Bore Ball Valve, Direct assembling, Threaded ends, Butt Weld, Socket Weld and Clamp



GENEBRE Ref.: 2025 - 2025N - 2025C - 2026 - 2027 - 2933

Installation, operation and maintenance instructions

| | |
|--|----|
| 1. Product description | 3 |
| 2. Transport and Storage conditions | 3 |
| 3. Valve breakdown | 4 |
| 3.1 Drawing and Components (Art. 2025 / 2025N / 2025C / 2026 / 2027) | 4 |
| 3.2 Drawing and Components (Art. 2933) | 5 |
| 4. Installation instructions | 6 |
| 4.1) Preparation..... | 6 |
| 4.2) Assembling..... | 7 |
| 5. Operating instructions | 8 |
| 5.1) Usage..... | 8 |
| 5.2) Manual operation | 9 |
| 5.3) Remote operation..... | 9 |
| 6. Maintenance instructions | 9 |
| 6.1) Stem leakage | 9 |
| 6.2) Body/Cap joint leakage | 9 |
| 6.3) Line leakage (through seats)..... | 10 |
| 7. Reparation instructions | 10 |
| 7.1) Disassembling..... | 10 |
| 7.2) Reassembling | 12 |
| 8. Torques table: | 13 |
| 9. Hygiene and Safety Instructions: | 14 |

1. Product description.

Genebre, S.A. offers a wide range of ball valves (90° turn), designed and assembled to handle and drive fluids in industrial procedures.

The compatibility of materials used to build the valves (see technical specifications) and the application of valves to the different industrial processes is at user's risk. Valves will have an optimal behaviour when working conditions do not exceed pressure and temperature limits (pressure curve) for which they have been designed. Please, refer to the product datasheet.

Ref. 2025: 3 pc. ball valve, threaded ends ISO 7

Ref.2025N: 3 pc. ball valve, threaded ends NPT

Ref.2025C: 3 pc. ball valve, threaded ends ISO 7, with Graphite ball seats

Ref.2026: 3 pc. ball valve, Butt Weld ends

Ref.2027: 3 pc. ball valve, Socket Weld ends

Ref.2933: 3 pc. ball valve, clamp ends BS, with integral ball seat

2. Transport and Storage conditions



Transport and storage of this type of products must be done in their original package

VISUAL INSPECTION

Check whether during transport, unloading and placement products have suffered any damage.

Manual valves are provided by default in an open position whereas automated valves are usually offered in a closed position due to the standard error position NC (normally closed). During storage it is recommended to keep them in this same position, with the included protective wrapping to avoid damages or dirt accumulation in the ball. The wrap must not be removed until valve is to be installed.

When possible, valves must be stored in a dry and clean environment.



If you notice any kind of anomaly during reception of the goods, contact immediately with GENE BRE in order to determine the possible responsibilities on the issue.

IMPORTANT NOTE:

Before installing and/or manipulating these elements **READ CAREFULLY** the enclosed instructions for use and **OBSERVE** all contained information. If any of the contents is not clear enough, please **contact GENEBRE, S.A.**



User is responsible for the safe use of these products, as established in present instructions for use and in the specific technical documentation of the supplied device.

3. Valve breakdown

3.1 Drawing and Components (Art. 2025 / 2025N / 2025C / 2026 / 2027)

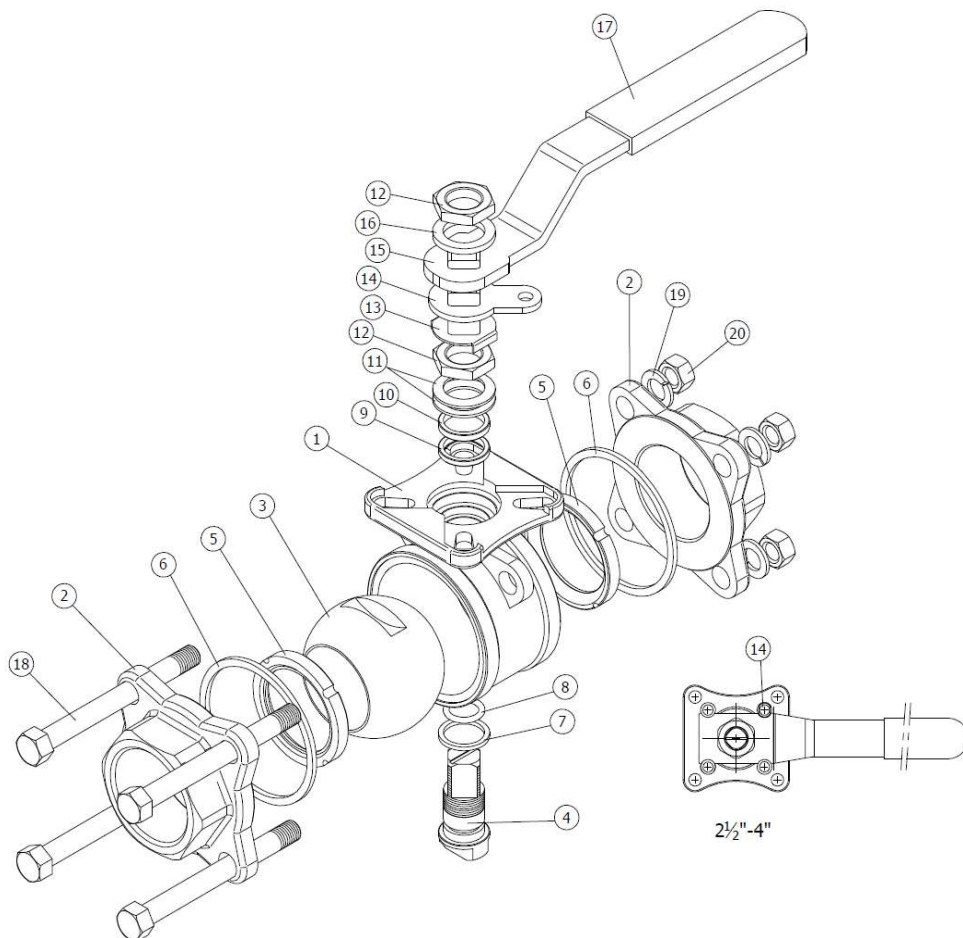

| Part. N° | Description | Qty | Material | Spare Part (ref.) |
|----------|-------------------|------|------------|---------------------|
| 1 | Body | 1 | 1.4408 | ---- |
| 2 | Cap | 2 | 1.4408 | ---- |
| 3 | Ball | 1 | 1.4408 | 2907 (2904 f/DN100) |
| 4 | Stem | 1 | AISI 316 | 2905 |
| 5 | Ball Seat | 2 | PTFE+FG* | 2820* |
| 6 | Gasket | 2 | PTFE+Graph | 2820 |
| 7 | Thrust Washer | 1 | PTFE+Graph | 2820 |
| 8 | O-ring | 1/2 | Viton | 2820 |
| 9 | Packing | 1 | PTFE | 2820 |
| 10 | Gland | 1 | AISI 304 | ---- |
| 11 | Belleville Washer | 2 | AISI 301 | ---- |
| 12 | Nut | 2 | AISI 304 | ---- |
| 13 | Locking Washer | 1 | AISI 304 | ---- |
| 14 | Stopper | 1 | AISI 304 | ---- |
| 15 | Handle | 1 | AISI 304 | ---- |
| 16 | Washer | 1 | AISI 304 | ---- |
| 17 | Handle Sleeve | 1 | Plastic | ---- |
| 18 | Screw/Bolt | 4/6 | AISI 304 | ---- |
| 19 | Washer | 4/12 | AISI 304 | ---- |
| 20 | Nut | 4/12 | AISI 304 | ---- |

* Article 2025C with ball seats made of PTFE+Graphite (Spare part ref. 2820C)

3.2 Drawing and Components (Art. 2933)

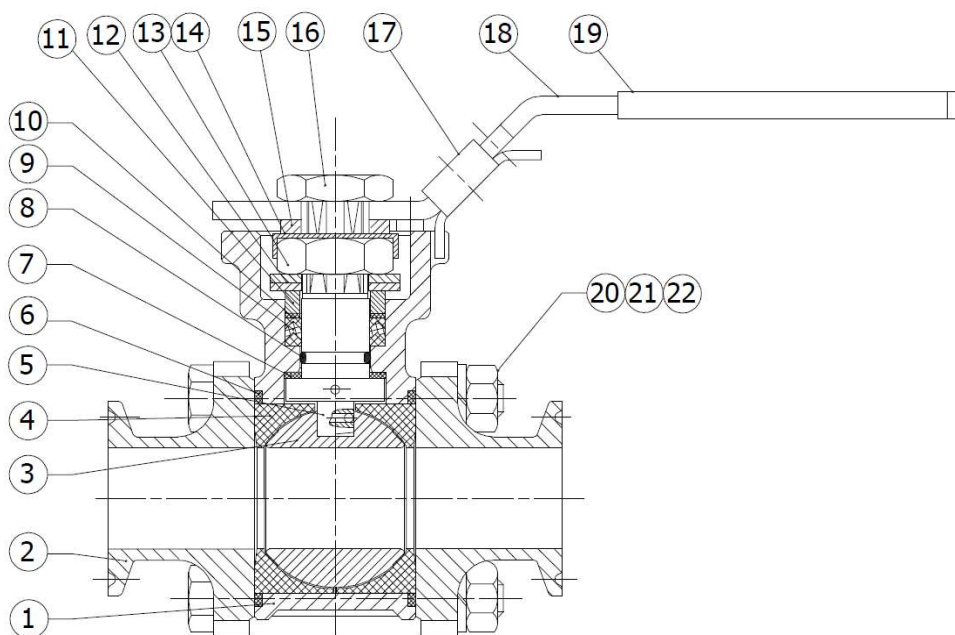

| Nº | Denominación / Name | Material | Acabado Superficial / Surface Treatment | Cód. Recambio Spare Part Code |
|----|---------------------------------------|--|---|-------------------------------|
| 1 | Cuerpo / Body | Acero Inox. / Stainless Steel 1.4408 | Electro pulido / Electro polish | ----- |
| 2 | Tapa / Cap | Acero Inox. / Stainless Steel 1.4408 | Electro pulido / Electro polish | ----- |
| 3 | Bola / Ball | Acero Inox. / Stainless Steel 1.4408 | Pulido / Polish | ----- |
| 4* | Asiento / Ball Seat | PTFE | ----- | K2933 |
| 5 | Eje / Stem | Acero Inox. / Stainless Steel AISI 316 | ----- | ----- |
| 6* | Junta / Gasket | PTFE | ----- | K2933 |
| 7* | Arandela / Thrust Washer | PTFE | ----- | K2933 |
| 8* | Junta tórica / O-ring | FPM | ----- | K2933 |
| 9* | Empaquetadura / Stem Packing | PTFE | ----- | K2933 |
| 10 | Anillo Prensa / Gland | Acero Inox. / Stainless Steel AISI 304 | ----- | ----- |
| 11 | Arandela Belleville/Belleville Washer | Acero Inox. / Stainless Steel AISI 301 | ----- | ----- |
| 12 | Tuerca Eje / Stem Nut | Acero Inox. / Stainless Steel AISI 304 | ----- | ----- |
| 13 | Antigiro / Lock Washer | Acero Inox. / Stainless Steel AISI 304 | ----- | ----- |
| 14 | Arandela / Washer | Acero Inox. / Stainless Steel AISI 304 | ----- | ----- |
| 15 | Tuerca Maneta / Handle Nut | Acero Inox. / Stainless Steel AISI 304 | ----- | ----- |
| 16 | Maneta / Handle | Acero Inox. / Stainless Steel AISI 304 | ----- | ----- |
| 17 | Funda / Handle Sleeve | Vinilo / Vynil | ----- | ----- |
| 18 | Tope / Stopper | Acero Inox. / Stainless Steel AISI 304 | ----- | ----- |
| 19 | Tuerca / Nut | Acero Inox. / Stainless Steel AISI 304 | ----- | ----- |
| 20 | Perno / Bolt | Acero Inox. / Stainless Steel AISI 304 | ----- | ----- |
| 21 | Arandela / Washer | Acero Inox. / Stainless Steel AISI 304 | ----- | ----- |
| 22 | Tuerca / Nut | Acero Inox. / Stainless Steel AISI 304 | ----- | ----- |

4. Installation instructions

4.1) Preparation

Remove any material remains of the valve wrapping.

Serious problems may arise with the installation of a valve in a dirty pipe.

Make sure the pipe is not dirty and doesn't have welding particles, for example, before installing it. This may cause irreparable damages in the valve when the equipment is started → *prepare a clean working area.*

Plan beforehand enough space for future maintenance operations.

Check correct performance of the valve by turning the handle clockwise and making sure the ball closes the fluid flow. If this is not the case, check if there are foreign particles inside the valve and repeat the whole operation.

In case of vibrations in the pipe it is strongly recommended to mount anti-vibration elements to absorb them. Otherwise, the life of the product could be drastically reduced.

4.2) Assembling

- Art. 2025 / 2025N / 2025C (threaded ends valve)

Do not disassemble the valves to install them.

Make sure the valve's pipe and thread ends are clean and are compatible one with another. Apply an appropriate seal in the pipe threads and screw in the valve, being careful not to tighten too much the conical threads.

Do not use the valve handle as a lever to screw the valve into the pipe.

To tighten the valve, it is recommended to use a spanner or a monkey wrench applying force only on the hexagonal edges of the valve. It is also recommended this force to be inferior to 30 Nm.

- Art. 2026 / 2027 (welded ends valve)

a) With the valve in a OPEN position, remove the *screws/bolts* (part.18), *washers* (part.19), *nuts* (part. 20) and *cap* (part.2).

b) Turn the ball until reaching the half-open position and remove the *seats* (part.5) and *gaskets* (part.6) of the *body* (part.1) carefully. Complete the turn until closing the valve and extract the *ball* (part.3). All components must be stored in a dry and clean environment.

c) Assemble back the *cap* (part.2) with the body, keeping them aligned as much as you can, using only 2 *screws* (part.18) diagonally opposed. Weld in least 4 different points (cross-shaped).

d) Remove the *body* (part.1) from the caps (to avoid welding temperature to damage PTFE stem washers) and complete the welding process by making sure the *caps* (part.2) are protected against welding metal spatters.

e) When cold, clean the *cap* sealing surface. Place the *ball* (part.3), *seats* (part.5) and *gaskets* (part.6) on the valve's body and turn the ball into open position. Place the valve body between the 2 caps being careful not to scratch the contact surfaces, then place the screws (Part.18) diagonally opposite adjusting until it becomes subject, place the valve in the closed position and tighten the screws to ensure contact metal - metal between body and ends (see recommended torques in Section 8.3).

- Art. 2933 (clamp ends valve)

It is not necessary to disassemble the valve in order to install it.

Make sure the pipe's clamp and the cap (part.2) clamp are clean. Place the silicone joints (art. 2987-Genebre) between the clamp ends to keep them tight and join them together with a quick locking binding clamp (art. 2986-Genebre) according to the size of valve.

IMPORTANT INFORMATION:

Design of this type of floating ball valves allows us to install them in any position as they are bidirectional, so the direction of fluid flow does not matter.

If possible, it is recommended to install the valve in horizontal position and the stem (handle) upwards.

Valves do not have to support pipe's efforts so it is advisable to anticipate a good alignment and parallelism of such pipe.

Once installed, it is recommended to open and close it a couple of times to verify its good performance and to check if there is any obstruction in the ball that prevents it from closing.

It is also recommended to use filters in the pipe to extend lifecycle of the valve.

5. Operational instructions

5.1) Usage

3 pieces full bore ball valves provide a leakproof lock when used adjusted to the pressure and temperature values for which they have been designed.

Avoid by all means to leave the valves in partially open position if you are not aware of the pressure drop and flow rate in that position, as the service life of the seat can be reduced and/or it can be damaged due to the ball bore valve.

Any fluid that can be solidified, crystallized or polymerized should not remain in the ball cavity as it is harmful for performance, service life of the valve and it can even render it unusable.

Seats for the valve, joints, body, ball, stem and ends have to be fully compatible with the fluid circulating through the valve. Otherwise, valve could be seriously damaged.

Torques required to operate valves are listed on the table in section 8.1.

5.2) Manual operation

When operating the valve you must avoid excessive lateral efforts with the handle. To close it, you must turn the handle 90 degrees clockwise. When the handle is in line with the pipe, valve is open.

In case you need to remove the handle to automate the valve, the *stem* (part. 4) has a mechanized linear mark at the front part that allows us to know its current position (opened or closed).

5.3) Remote operation

When automation of 3 piece valves is required, GENE BRE S.A. can provide a great variety of pneumatic actuators, electric actuators, electropneumatic and electronic positioners to cover a large range of operations.

6. Maintenance instructions

Frequency, location and process of maintenance will be determined by the user by taking into account usage of the product. However, periodical checks explained below will be useful to extend the service life of the valve and reduce installation problems:

Valves must not remain in open or closed position for a long period of time. It is recommended, if the process allows it, to proceed to an operational task for the valve every six months.

6.1) Stem leakage

Remove the handle or actuator, the *locking washer* (part.13) and tighten the *nut* (part.12) of the stem packing (see *Section 8.2*). If the leakage persists, valve should be disassembled to replace the *stem washers* (part.7,8,9).

See reparation instructions.

6.2) Body/Cap joint leakage

Check if the body *screws* (part.18 / part.20 Art.2933) are tightened. If they were loose, adjust them up until the recommended torques (IMPORTANT: adjustment of such screws will have to be done at room temperature). If leakage continues, it is probably due to a damage in the body gasket or the locking surface, and it will be necessary to disassemble the valve to repair it.

See reparation instructions.

6.3) Line leakage (through seats).

Check if the valve is in a completely closed position. If this is the case, leakage is due to a seat or locking surface being damaged and it will be necessary to disassemble the valve for repairing it.

See reparation instructions.

7. Reparation instructions



Before disassembling the pipe's valve to repair or replace it, make sure that line has been closed and depressurized because a bad operational procedure could cause a serious accident to you or to the installation system

7.1) Disassembling

To proceed to repair it, it is not necessary to remove the valve from the installation as the 3-pieces design for the valve allows us to remove the central part (body with all internal components) without having to disassemble the terminals.

Prepare a clean working area and adequate tools to perform mechanical tasks.

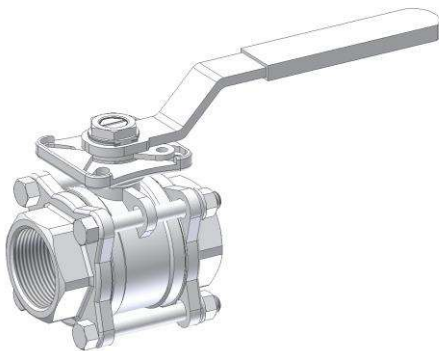

a.- Place the valve in an OPEN position to avoid the ball from standing out of the body and interfere with the ends when the body is removed.

Remember that the stem has a line in the frontal part to indicate position of the valve:

- parallel to pipe → open valve,
- perpendicular to pipe → closed valve,

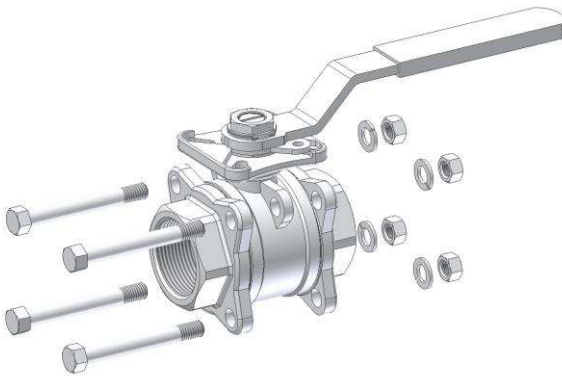

b.- Loosen and remove the the *nuts* (part. 20 / part. 22 Art.2933) of the *screws / bolts* (part. 18 / part. 20 Art.2933) that bring together the three different parts of the valve. Remove the screws.

Be careful not to damage the cap surfaces.

c.- Remove the central group separating it from the *caps* (part. 2).

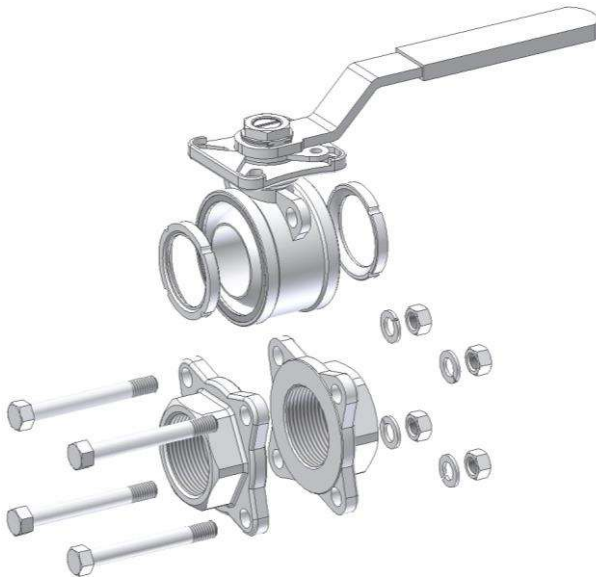

d.- Once the body is out, place the *ball* (part. 3) in a half-open position (45°, for example) and remove the *seats* (part. 5 / part. 4 Art.2933). Complete the turn of the ball until closed position and then it can be removed. This operation has to be performed carefully, otherwise the ball could be marked against the body.

e.- After this, remove the body *Gasket* (part.6). They should be removed being carefully not to scratch or damage the mechanized surfaces over which they are hermetically sealed.

f.-To disassemble the *stem* (part. 4 / part. 5 Art.2933), remove the following elements:

| Name | Art. 2025 / 2025N / 2026 / 2027 | Art. 2933 |
|----------------|---------------------------------|-----------|
| Handle nut | Part.12 | Part.15 |
| Washer | Part.16 | Part.14 |
| Handle | Part.15 | Part.16 |
| Locking washer | Part.13 | Part.13 |
| Nut | Part.12 | Part.12 |
| Spring washers | Part.11 | Part.11 |
| Packing | Part.10 | Part.10 |

Push the stem inside the body and then remove it. Later, remove the *packing* (part. 9) located inside the body. Remove the *o'ring* (part. 8) from its location and also the *thrust washer* (part. 7).

g.- Once the valve is disassembled you must verify the state of each single piece that compose it. All pieces to be reused have to be cleaned completely and be kept in a safe and clean environment.

All sealing surfaces in the ball, seats, joints and faces have to be checked for corrosion, erosion, metallic inlays in the seats and marks. If they were damaged or in case of doubt, they will need to be replaced.

h.- Cleaning of the valve's pieces must be done using an adequate degreasing agent. You must be careful with the locking surfaces, for example, of the ball, locking sides of the ends and joints, because if they were damaged this could cause a bad impact in the valve's performance.

7.2) Reassembling

Before proceeding to reassemble the valve, make sure that reparation kit and/or pieces to be used are appropriate and original from the factory.

When it is assembled again, cleaning is essential for a long life for the valve.

a.- Place a new thrust *washer* (part. 7) on the *stem* (part. 4 / part. 5 Art.2933) and also the *o-ring / o-rings* (part. 8) in its stem corresponding location, lubricate the stem with a thin layer of grease or silicon (for example, Dow Corning 200) and insert it in the valve's *body* (part.1), in the inside cavity, by pushing a bit to fix it.

b.- Place a new packing (part. 9) from its location in the upper cavity of the *body* (part.1), the *gland* (part. 10) and the *spring washers* (part. 11) with both external borders together (concave position). Place the *nut* (part. 12), tighten it and turn the stem a couple of times. Then, readjust the nut taking into account the specified torque value (see *Section 8.2*).

If necessary, fasten with a wrench the internal body of the stem to tighten properly the nut without making the stem turn.

It is convenient to match one of the nut vertexes with one of the stem vertexes to be able to insert the lock nut (part. 13) later on.

Note that if the nut is too tight, the rod torque will increase and service life of its elements will be reduced.

c.- Place the stem in a closed valve position and insert the *ball* (part. 3) inside the *body* (part. 1) matching the ball slot with *stem* groove (part. 4 / part. 5 Art.2933). Open the valve so that the ball does not fall.

d.- New *seats* (part. 5 / part.4 Art.2933) and body *gasket* (part. 6) can now be placed on both sides of the body, always keeping flat part of the seat facing outward.

e.- The *caps* (part. 2) must be clean in their sealing areas before proceeding to final assembling.

Place the central valve group between the caps and screw the bolts/screws (part. 18 / part. 20 Art.2933) to bring together the three different parts of the valve.

It is really important that all pieces, such as *caps* (part. 2), *ball* (part. 3) and *seats* (part. 5 / part. 4 Art.2933) are completely aligned inside.

f.- Then, proceed to place the *nuts* (part. 12 / part. 22 Art.2933) adjusting slowly and alternating diagonal until the body becomes subject, place the valve in the closed position and tighten the screws to ensure contact metal - metal between body and ends (see recommended torques in Section 8.3).

8. Torque table:

8.1) Breakaway torque:

| MEASURE | Breakaway torque (N.m.) |
|---------|-------------------------|
| 1/4" | 4 – 5 |
| 3/8" | 4 – 5 |
| 1/2" | 4 – 5 |
| 3/4" | 7 – 8 |
| 1" | 9 – 10 |
| 1 1/4" | 12 – 14 |
| 1 1/2" | 18 – 20 |
| 2" | 28 – 30 |
| 2 1/2" | 34 – 36 |
| 3" | 58 – 60 |
| 4" | 90 – 95 |

8.2) Torques for the stem nut:

Following numerical data is provided as reference only. Specified torques are the ones used to operate the assembled stem before assembling ball and seats.

| Valve size | Breakaway torque (N·m) |
|----------------------|------------------------|
| 1/4" - 3/8" - 1/2" | 6 - 9 |
| 3/4" - 1" | 8 - 12 |
| 1 1/4" - 1 1/2" - 2" | 13 - 18 |
| 2 1/2" - 3" - 4" | 19 - 24,5 |

8.3) Tightening torque Screws/ Nuts for joining the valve's different parts:

Important: The screws must ensure contact metal - metal between body and ends.

These values are appropriate (guidance) by manufacturers of screws / nuts, for our case has been considered hexagon screws DIN 931/933 and nuts DIN 934 type stainless steel A2 Class 70:

| Valve size | Screw / Nut | Max. torque (N.m.) |
|----------------------|-------------|--------------------|
| 1/4" - 3/8" - 1/2" | M6 | 6 |
| 3/4" - 1" | M8 | 15 |
| 1 1/4" - 1 1/2" - 2" | M10 | 30 |
| 2 1/2" - 3" - 4" | 1/2" W | 50 |

9. Hygiene and Safety Instructions:

9.1) Fluids that go through a valve can be corrosive, toxic, flammable or pollutant. They can also be found at very high or low temperature. When operating valves, you must follow the security instructions and it is recommended to use personal protection gadgets:

- 1) Protect your eyes.
- 2) Wear gloves and appropriate working clothes.
- 3) Wear safety footwear.
- 4) Wear a helmet.
- 5) Have running water at hand.
- 6) To operate flammable fluids, make sure you have an extinguisher at hand.



Before removing a valve from a pipe, always check if the line is completely drained and depressurized.

9.2) Always operate the valve in open position to make sure there is no pressure in the internal cavity.

9.3) Any valve being used by toxic services department needs to obtain a cleanliness certificate before being operated.

9.4) Any type of repair or maintenance should be performed in ventilated places.



PT. LAMINDO PRIMA MANDIRI

Ciputra International Office Tower 3, 12th Floor
Jl. Lingkar Luar Barat, Block A No. 1 Rawa Buaya, Cengkareng – West Jakarta 11740A