

INSTALLATION, OPERATION AND MAINTENANCE MANUAL

Flanged ends Gate Valve



Ref. GENE BRE: 2229A

Installation, operation and maintenance instructions

1. Product description	3
2. Transport and Storage conditions	3
3. Exploded drawing	4
4. Installation instructions	5
4.1 Preparation	5
4.2 Installation of valves with flanged ends	6
5. Operating instructions	
5.1 Usage	6
5.2 Manual operation	7
6. Maintenance instructions	7
7. Reparation instructions	8
8. Hygiene and Safety Instructions	8

1. Product description.

Genebre, S.A. offers a wide range of valves designed and assembled to handwheel and drive fluids in industrial procedures.

The compatibility of materials used to build the valves (see technical specifications) and the application of valves to the different industrial processes is at user's risk. Valves will have an optimal behavior when working conditions do not exceed pressure and temperature limits (pressure curve) for which they have been designed.

2. Transport and Storage conditions



Transport and storage of this kind of products must be done keeping them in their original package!

VISUAL INSPECTION

Check whether during transport, unloading and placement the products have suffered damages.

During storage it is recommended to keep them into the included protective wrapping to avoid damages or dirt accumulation in the inside part of the valve. The wrap must not be removed until valve is to be installed.

Valves must be stored in a dry and clean environment.



If you notice any kind of anomaly during reception of the goods, contact immediately with GENE BRE in order to determine the possible responsibilities on the issue.

IMPORTANT NOTE:

Before installing and/or manipulating these elements, READ CAREFULLY these instructions for use and OBSERVE all contained information. If you fail to understand any of their content, please contact GENE BRE, S.A.



User is responsible for the safe use of these products, according to present instructions for use and specific technical documentation of the device.

3. Exploded drawing

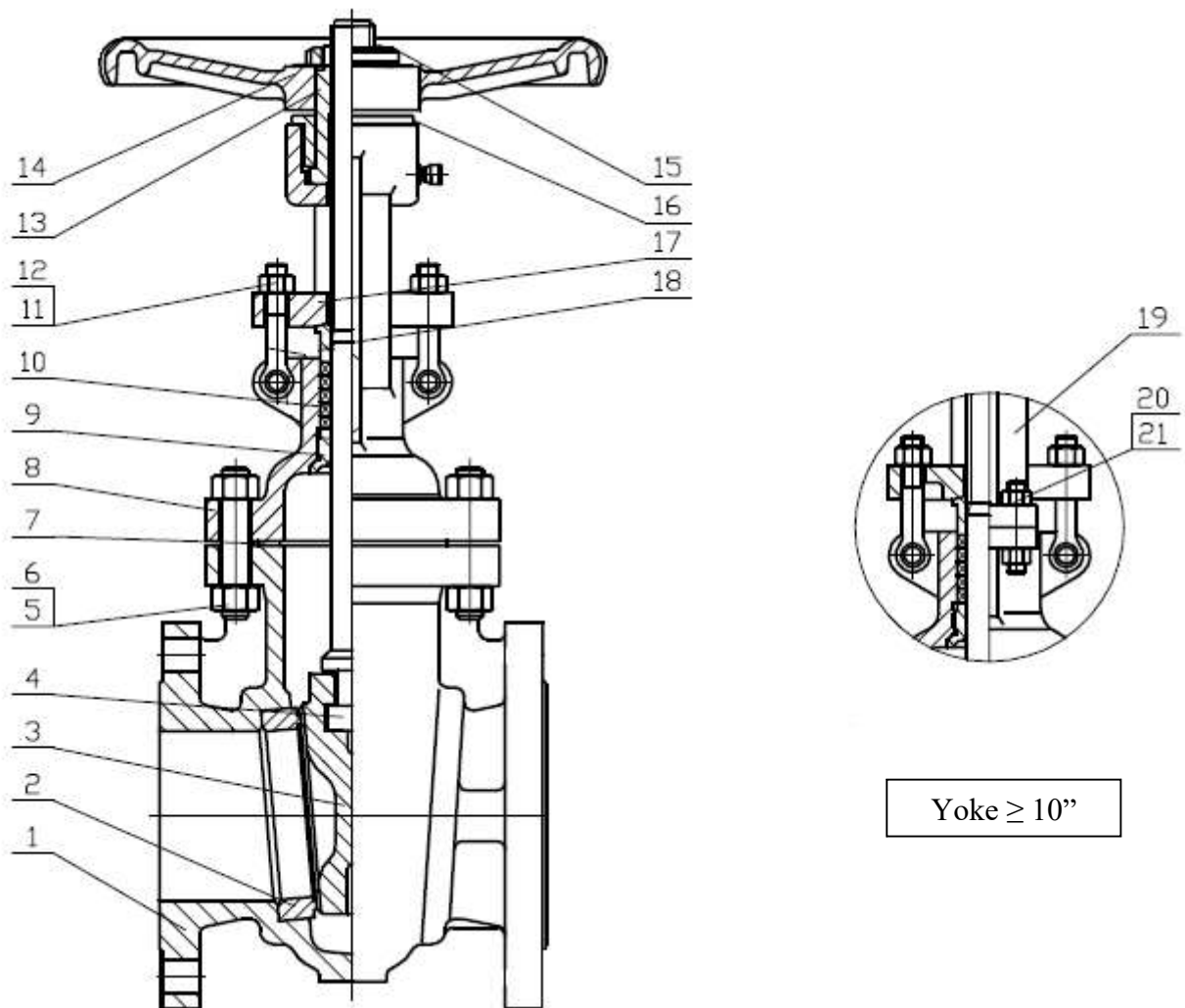

Nº	Name	Material	Surface Treatment
1	<i>Body</i>	ASTM A216 WCB	<i>Painted</i>
2	<i>Seat</i>	ASTM A105 + 13 Cr	-----
3	<i>Wedge Disc</i>	ASTM A216 WCB + 13 Cr	-----
4	<i>Stem</i>	ASTM A276 - 410	-----
5	<i>Bonnet Bolt</i>	ASTM A193 Gr. B7	-----
6	<i>Bonnet Nut</i>	ASTM A194 Gr. 2H	-----
7	<i>Body Gasket</i>	S.S 304 + <i>Graphite</i>	-----
8	<i>Bonnet</i>	ASTM A216 WCB	<i>Painted</i>
9	<i>Back Seat Bushing</i>	ASTM A276 - 410	-----
10	<i>Stem packing</i>	<i>Graphite</i>	-----
11	<i>Bolt</i>	ASTM A193 Gr. B7	-----
12	<i>Nut</i>	ASTM A194 Gr. 2H	-----
13	<i>Stem Nut</i>	ASTM A536 80-55-06	-----
14	<i>Handwheel</i>	<i>Cast Iron</i>	<i>Painted</i>
15	<i>Handwheel Nut</i>	<i>Carbon steel</i>	-----
16	<i>Gland Nut</i>	<i>Carbon steel</i>	-----
17	<i>Gland Flange</i>	ASTM A105	-----
18	<i>Gland</i>	ASTM A276 - 410	-----
19	<i>Yoke</i>	ASTM A216 WCB	<i>Painted</i>
20	<i>Yoke Bolt</i>	ASTM A193 Gr. B7	-----
21	<i>Yoke Nut</i>	ASTM A194 Gr. 2H	-----

4. Installation instructions

4.1) Preparation

Remove any material remains of the valve wrapping.

Serious problems may arise with the installation of a valve in a dirty pipe.

Make sure the pipe is not dirty and doesn't have welding particles, for example, before installing it. This may cause irreparable damages in the valve when the equipment is started → *prepare a clean working area.*

Plan beforehand enough space for future maintenance operations.

Control the correct performance of the valve by turning the handwheel both sides (close and open) and observing if the disc or needle slides correctly. If this is not the case, check if there are foreign particles inside the valve and repeat the whole operation.

In case of vibrations in the pipe it is strongly recommended to mount anti-vibration elements to absorb them. Otherwise, the life of the product could be drastically reduced

4.2) Installation of valves with flanged ends

Do not disassemble the valves to install them.

Make sure the pipe's and edges flanges of the valve are clean.

Use the corresponding screws in all of the flanges drill holes.

Place an adequate joint in each end and align it in the center of the flanges.

Tighten screws evenly and cross-shaped to avoid deformations. To do so, you must not force in any case the pipe to center the valve; it should take its position smoothly. Last, verify that screws are tightened with the recommended torque for each type of screw.

Make sure the flanges joints are well placed.

After assembling, check the tightness and performance of the valve.

Valves do not have to support pipe's efforts so it is advisable to anticipate a good alignment and parallelism of such pipe.

It is also recommended to use filters in the pipe to extend lifecycle of the valve.

When installed on steam systems a suitable steam trap should be fitted immediately upstream of the isolation valve to drain condensate. This will ensure drainage of the pipe when the valve is closed and will prevent damage of the valve due to waterhammer.

5. Operating instructions

5.1) Usage

GENEBRE valves provide a leakproof lock when used adjusted to the pressure and temperature values for which they have been designed.

Valve materials have to be fully compatible with the fluid circulating through the valve. Otherwise, valve could be seriously damaged.

Do not use for slurries or fluids containing solids that can build up in valve cavities.

5.2) Manual operation

When operating the valve, you must avoid excessive lateral efforts with the handwheel. To close, the operation consists in turning the handwheel clockwise and anticlockwise if you want to open the valve.

Always open isolation valves slowly to avoid system shocks.

6. Maintenance instructions

Frequency, place and process of maintenance will be determined by the user by taking into account usage of the product. However, periodical checks explained below will be useful to extend the service life of the valve and reduce installation problems.

6.1) Valves must not remain in open or closed position for a long period of time. It is recommended, if the process allows for it, to operate it for control purposes every six months.

6.2) Verify possible leaks in the stem area; in case they exist, it is likely that the bellows is damaged; valve should be replaced (*see section 6*).

6.3) Verify possible leaks through the line (due to closure); this defect is probably caused by deposition of impurities between the disc or needle and the seat, transported by the fluid. Disassemble the valve from the pipe, clean it thoroughly and reinstall it. If the problem persists you should change the valve, since it is possible that some metallic parts used for closure are damaged (erosion, corrosion). See section 6 for further details.

6.4) Keep the stem well greased, for it use the lubricating nipple.
“Pay attention, that the lubricant is suitable for the media”.

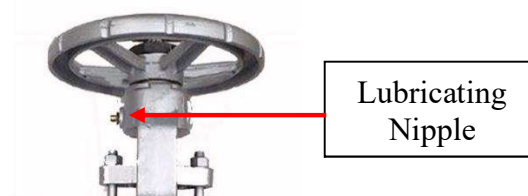

7. Reparation instructions

These types of valves, due to their assembling specifications are not worth repairing, because most of the times are simply not cost-effective, so we recommend to directly replace them.



Before disassembling the pipe's valve to clean or replace it, make sure that line has been closed and depressurized because a bad operational procedure could cause a serious accident to staff and installation system



Before installing new valve, check if it meets the requirements of the valve being replaced

8. Hygiene and Safety Instructions

8.1) Fluid passing through a valve or accessory can be corrosive, toxic, flammable or pollutant. They can also be found at very high or low temperature. When operating valves, you must follow the security instructions and it is recommended to use personal protection gadgets:

- 1) Protect your eyes.
- 2) Wear gloves and appropriate working clothes.
- 3) Wear safety footwear.
- 4) Wear a helmet.
- 5) Have running water at hand.
- 6) To operate flammable fluids, make sure you have an extinguisher at hand.

8.2) Before removing a valve from a pipe, check always if the line is completely drained and depressurized.

8.3) Operate the valve in open position to make sure there is no pressure in the internal cavity.

8.4) Any valve being used by toxic services department needs to obtain a cleanliness certificate before being operated.

8.5) Any type of repair or maintenance should be performed in ventilated places.



PT. LAMINDO PRIMA MANDIRI

Ciputra International Office Tower 3, 12th Floor
Jl. Lingkar Luar Barat, Block A No. 1 Rawa Buaya, Cengkareng – West Jakarta 11740A