

Art. 8112N

Manifold 2, 3 o 5 válvulas - montaje a distancia Manifold 2, 3 or 5 valves - remote operation

Características	Features
<ul style="list-style-type: none"> <input type="checkbox"/> Manifold para instrumentación de 2, 3 o 5 válvulas. <input type="checkbox"/> Montaje a distancia. <input type="checkbox"/> Diseñado para aplicaciones en presiones estáticas, diferenciales o nivel de líquidos. <input type="checkbox"/> Construcción en acero inoxidable 316. <input type="checkbox"/> Cierre metal / metal. <input type="checkbox"/> Empaquetadura: PTFE. <input type="checkbox"/> Pin de bloqueo de seguridad: evita la desconexión accidental del bonete de la válvula debido a vibraciones. <input type="checkbox"/> Presión de trabajo hasta 414 bar (6000 psi). <input type="checkbox"/> Temperatura de trabajo -54°C – 232°C. 	<ul style="list-style-type: none"> <input type="checkbox"/> <i>Instrument manifold with 2, 3 or 5 valves.</i> <input type="checkbox"/> <i>Remote Operation.</i> <input type="checkbox"/> <i>Designed for static pressure, differential pressure or liquid level applications.</i> <input type="checkbox"/> <i>Made of stainless steel AISI 316.</i> <input type="checkbox"/> <i>Metal-to-metal sealing.</i> <input type="checkbox"/> <i>Packing: PTFE.</i> <input type="checkbox"/> <i>Safety stop pin: This device prevents detachment of the bonnet from the body due to vibration.</i> <input type="checkbox"/> <i>Working pressure up to 414 bar (6000 psi).</i> <input type="checkbox"/> <i>Working temperature -54°C – 232°C.</i>

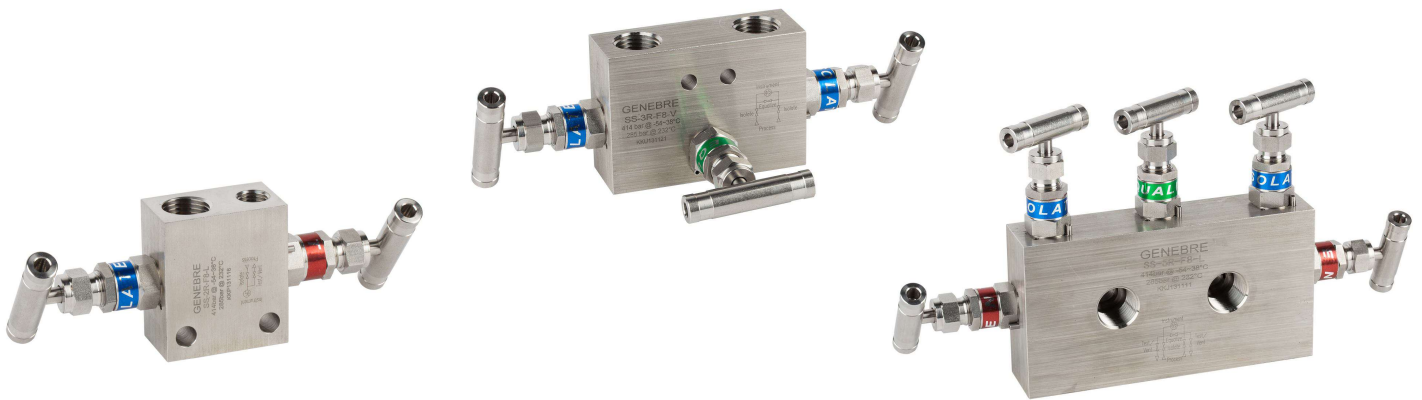

Nº	Denominación / Name	Material
1	Maneta / Handle	Acero Inox AISI 304 / SS 304
2	Prisionero / Set Screw	Acero Inox AISI 304 / SS 304
3	Tuerca Prensa / Packing Nut	Acero Inox AISI 321 / SS 321
4	Eje Superior / Upper Stem	Acero Inox AISI 316 / SS 316
5	Tuerca Bloqueo / Lock Nut	Acero Inox AISI 316 / SS 316
6	Bonete / Bonnet	Acero Inox AISI 316 / SS 316
7	Prensaestopa / Gland	Acero Inox AISI 316 / SS 316
8	Empaquetadura / Packing	PTFE
9	Pin Bloqueo / Lock Pin	Acero Inox AISI 304 / SS 304
10	Eje Inferior / Lower Stem	Acero Inox AISI 316 / SS 316
11	Cuerpo / Body	Acero Inox AISI 316 / SS 316

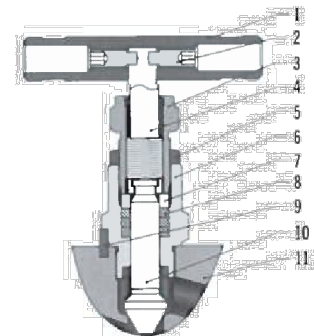

DIMENSIONES GENERALES / GENERAL DIMENSIONS

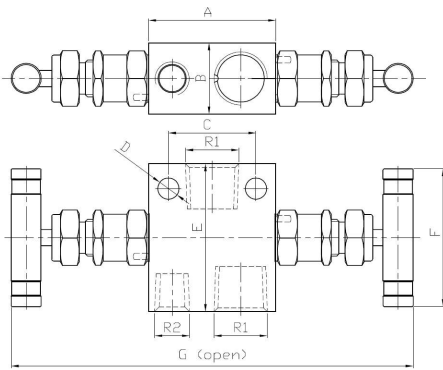

8112N 04 02

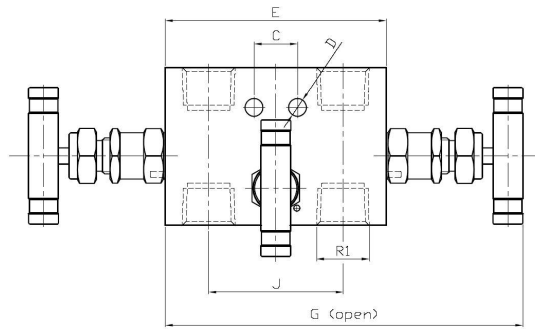

8112N 04 03

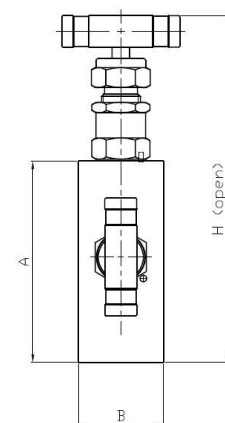
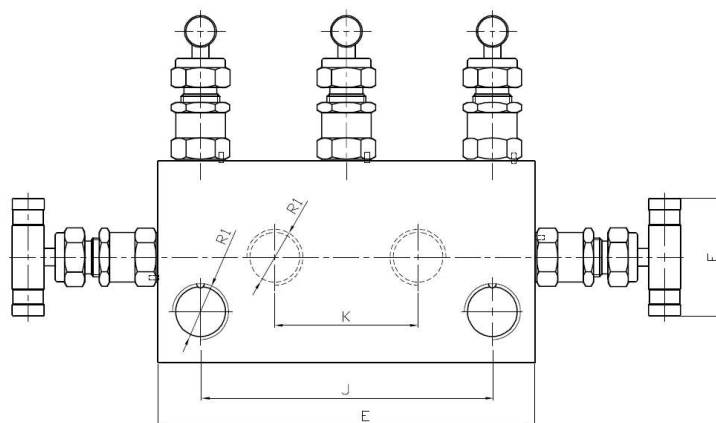
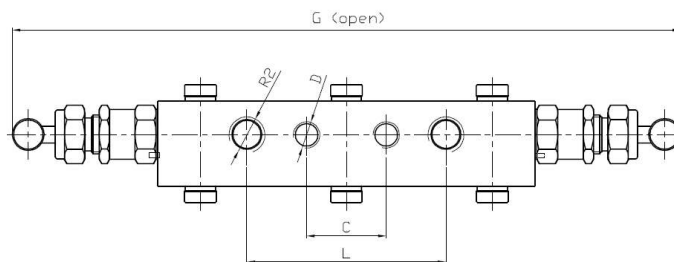
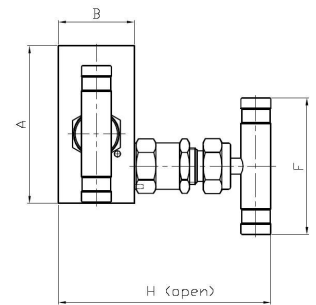

8112N 04 05

Ref.	Dimensiones / Dimensions (mm)													Peso/ Weight (Kg)
	A	B	C	D	E	F	G	H	J	K	L	R1	R2	
8112N 04 02	51	28,5	35	Ø8,5	59	55	170	-	-	-	-	1/2" NPT	1/4" NPT	0,750
8112N 04 03	63	30,5	17	Ø7,2	89	55	209	90,5	54	-	-	1/2" NPT	-	1,530
8112N 04 05	76	32	30	M10	142	45	264	136	110	54	75	1/2" NPT	1/4" NPT	2,950

DIAGRAMA DE FUNCIONAMIENTO / OPERATING DIAGRAM

8112N 04 02 →

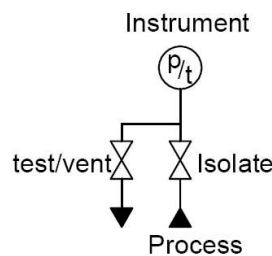

2 válvulas en un bloque, diseñado para el bloqueo y purga de manómetros, presostatos y transmisores de presión estática / *2 valves in one block, designed for blocking and bleeding of manometers, pressure switches and static pressure transmitters.*

8112N 04 03 →

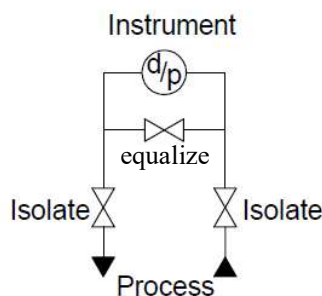

3 válvulas en un bloque, están diseñados con dos válvulas principales de bloqueo y una equalizadora para el montaje de manómetros y transmisores de presión diferencial / *3 valves in one block, are designed with two main block valves and equalizer one (by pass) for manifolding all kinds of differential pressure instruments.*

8112N 04 05 →

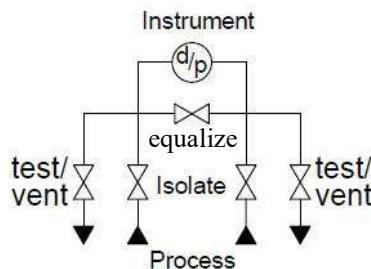

5 válvulas en un bloque, similar a manifold de 3 válvulas agregando del lado del lado instrumento dos válvulas adicionales para purga o calibración. / *5 valves in one block, similar to 3 valves in one block adding two valves in the instrument side for venting or calibration.*