

## **Art. 5800 ACTUADOR NEUMATICO DE ALUMINIO – Gen-Air** **Art. 5800 PNEUMATIC ACTUATORS IN ALUMINIUM – Gen-Air**

<b>Características</b>	<b>Features</b>
<ol style="list-style-type: none"><li>1. Los actuadores neumáticos con piñón y cremallera, disponibles en doble y simple efecto, han sido proyectados con un diseño compacto y efectúan un par lineal en toda su carrera.</li><li>2. Cuerpo de aluminio extruido según ASTM 6005, con anodizado como protección a la corrosión interna y externa, con fino acabado interno del cilindro para obtener un bajo coeficiente de fricción.</li><li>3. Toda la serie de actuadores han sido proyectados según las normas Namur VDI/VDE 3845 e ISO 5211, que permiten el montaje directamente de electroválvulas, caja de interruptores, posicionadores, etc.</li><li>4. El ángulo estándar de rotación es de 90°; están disponibles bajo pedido las versiones a 120°, 135°, 150° y 180°.</li><li>5. Indicadores de posición externos en la dotación estándar.</li><li>6. La altura del piñón (NAMUR H = 30) permite efectuar acciones manuales de emergencia sin interferir con el indicador.</li><li>7. La presión a la cual es posible trabajar está comprendida entre 2 y 10 bar. Preferentemente, utilizar aire comprimido filtrado, seco o mejor lubricado.</li><li>8. La conexión hembra del piñón es, en la configuración estándar, un Doble Cuadrado.</li><li>9. Los muelles, construidos en acero especial con recubrimiento anticorrosivo, están pre montados solamente con material tecno-polímero.</li><li>10. Todas las unidades están lubricadas en fase de montaje, con grasa sin base de silicona.</li><li>11. Todos los tornillos y tuercas externas son de acero inoxidable.</li></ol>	<ol style="list-style-type: none"><li>1. <i>The pneumatic actuators with rack &amp; pinion, available in double acting and spring return, have been projected with a compact design performing a linear torque in their entire stroke.</i></li><li>2. <i>Extruded aluminium ASTM6005 body with internal surface having honed cylinder for longer life and low friction coefficient, and both internal and external corrosion protection treated with anodized.</i></li><li>3. <i>The whole actuators series have been projected according to the standards Namur VDI/VDE 3845 and ISO 5211 which allow the direct assembling of solenoid valves, switch boxes, positioners, etc.</i></li><li>4. <i>The standard angle of rotation is 90°; other versions such as 120°, 135°, 150° and 180° are available on demand.</i></li><li>5. <i>External indicators open / closed in all the range.</i></li><li>6. <i>The height of the pinion (NAMUR H = 30) allows to make manual actions of emergency without interfering with the indicator.</i></li><li>7. <i>The working pressure is between 2 and 10 bar. The most suitable fluid to be used is filtered compressed air (dry or even better lubricated).</i></li><li>8. <i>The female connection of the pinion drive is double square.</i></li><li>9. <i>Epoxy coated special steel springs are preloaded with non-metallic materials. All parts are corrosion resistance.</i></li><li>10. <i>All units are lubricated during assembly phase with non-silicone grease.</i></li><li>11. <i>All the screws and external nuts are made of stainless steel.</i></li></ol>



## CONDICIONES DE TRABAJO

- 1. Fluidos de accionamiento**  
Aire seco o lubricado, Gases no corrosivos.
- 2. Presión de suministro de aire**  
2 ~ 10 bar
- 3. Temperatura de funcionamiento**  
Estándar: -20°C +80°C.  
Opcional Art. 5800H para uso a alta temperatura -23°C +120°C (hasta +150°C para uso esporádico), con juntas de FPM (Viton).
- 4. Ajuste del Recorrido**  
Tiene un rango de ajuste de  $\pm 10^\circ$  para la rotación en  $90^\circ$ .
- 5. Lubricación**  
No necesita acrecentar el lubricante en condiciones normales de trabajo.
- 6. Presión máxima de aire**  
10 bar

## OPERATING CONDITIONS

- 1. Operating media**  
*Dry or lubricated air, non-corrosive gases.*
- 2. Air supply pressure**  
*2 ~ 10 bar*
- 3. Operating temperature**  
Standard: -20°C +80°C.  
Optional Art. 5800H for use at high temperature -23°C +120°C (until +150°C for cyclic use), with FPM (Viton) seals.
- 4. Travel adjustment**  
*Adjustment range of  $\pm 10^\circ$  for the rotation at  $90^\circ$ .*
- 5. Lubrication**  
*Under normal operating conditions, there is no need to add lubricant.*
- 6. Maximum air pressure**  
*10 bar*

## DESPIECE Y RECAMBIOS

## ASSEMBLE AND PARTS

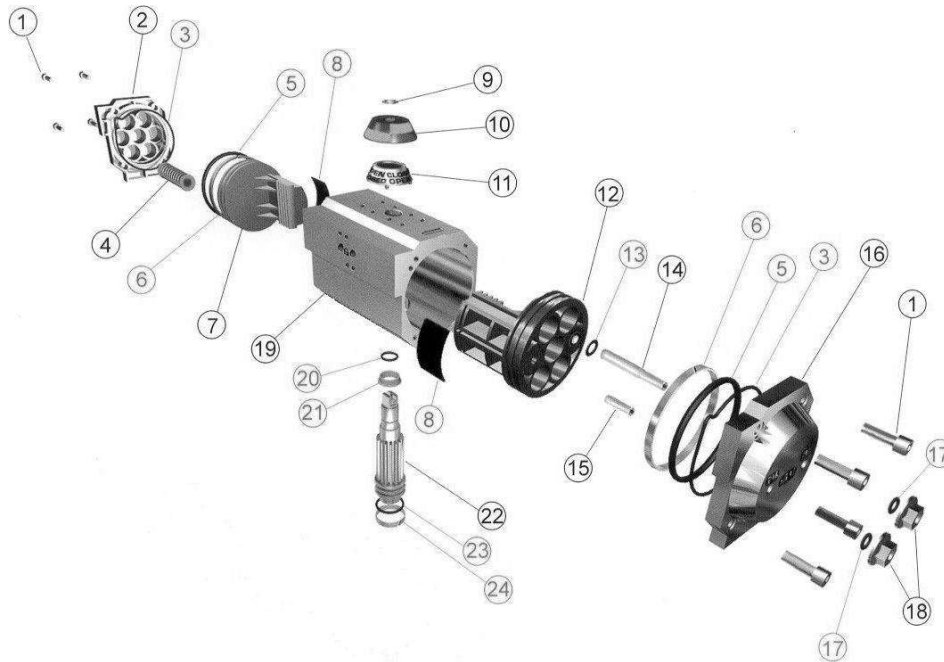

Nº	Denominación / Name	Material / Material	Cód. Recambio / Spare Part Code
1	Tornillo cabezales / End cap screw	Acero Inox. / Stainless steel AISI 304	-----
2*	Cabezal izquierdo / Left end cap	Aluminio / Aluminium UNI 5076	TGN xxI
3*	O-ring cabezal / End cap o-ring	NBR	KGNxx
4*	Cartucho muelles / Spring cartridge	Acero para muelles / Spring steel	C5800 xx
5*	O-ring piston / Piston o-ring	NBR	KGNxx
6	Anillo guía / Guide ring	Tecno – polímero / Techno - polymer	-----
7*	Pistón izquierdo / Left piston	Aluminio / Aluminium UNI 5076	EMBxx
8	Patín pistón / Piston Skate	Tecno – polímero / Techno - polymer	-----
9	Seeger indicador / Indicator snap ring	Acero Inox. / Stainless steel AISI 304	-----
10	Indicador (parte móvil) / Indicator (rotating part)	Tecno – polímero / Techno - polymer	-----
11	Indicador (parte fija) / Indicator (fix part)	Tecno – polímero / Techno - polymer	-----
12*	Pistón derecho / Right piston	Aluminio / Aluminium UNI 5076	EMBxx
13*	O-ring eje de regulación / Stem regulation o - ring	NBR	KGNxx
14	Eje de regulación / Regulation screw	Acero Inox. / Stainless steel AISI 304	-----
15	Prisionero de regulación / Stop bolt	Acero Inox. / Stainless steel AISI 304	-----
16*	Cabezal derecho / Right end cap	Aluminio / Aluminium UNI 5076	TGN xxD
17*	O-ring tuerca registro / Stop bolt nut o - ring	NBR	KGNxx
18	Tuerca de registro / Stop bolt nut	Acero Inox. / Stainless steel AISI 304	-----
19	Cuerpo actuador / Actuator body	Aluminio / Aluminium ASTM B 210 (6063)	-----
20*	O-ring superior piñón / Upper pinion o - ring	NBR	KGNxx
21	Anillo guía piñón superior / Upper pinion bearing	Tecno – polímero / Techno - polymer	-----
22	Piñón / Pinion	Acero / Steel nickel plated ASTM B 733	-----
23*	O-ring inferior piñón / Lower pinion o-ring	NBR	KGNxx
24	Anillo guía piñón inferior / Lower pinion bearing	Tecno – polímero / Techno - polymer	-----

\* Piezas de recambio disponibles / Available spare parts

## Esquema de Funcionamiento

## Operating Diagram

### Doble Efecto / Double Acting

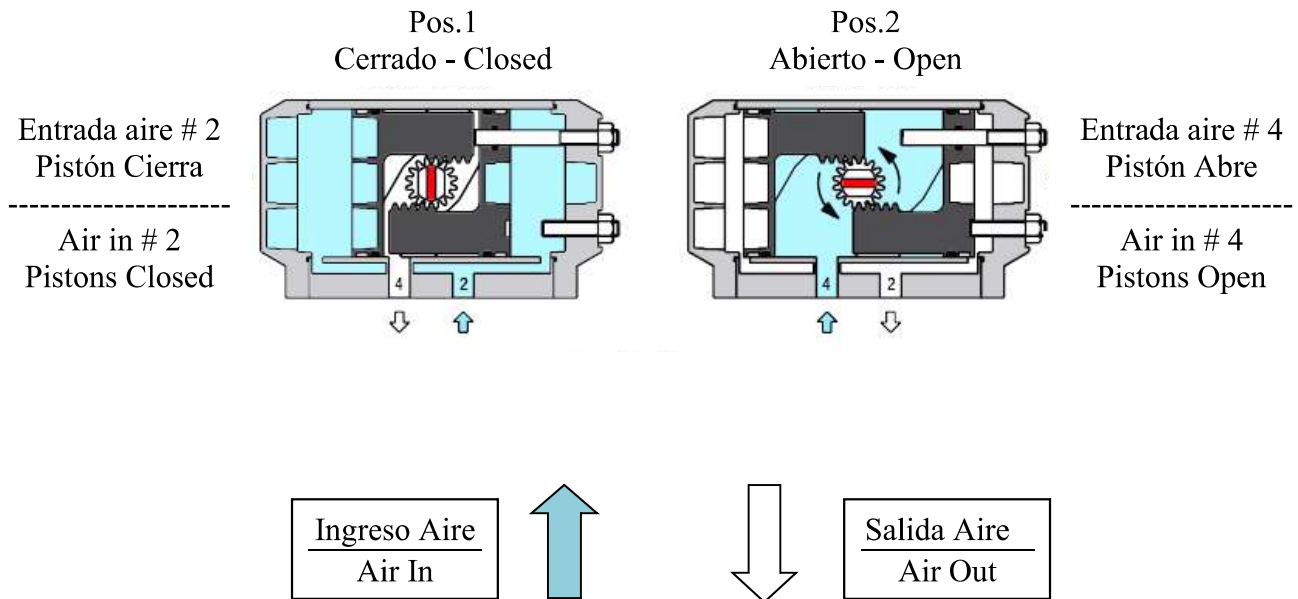

### Simple Efecto / Spring Return

#### Fase de Apertura – Opening Phase

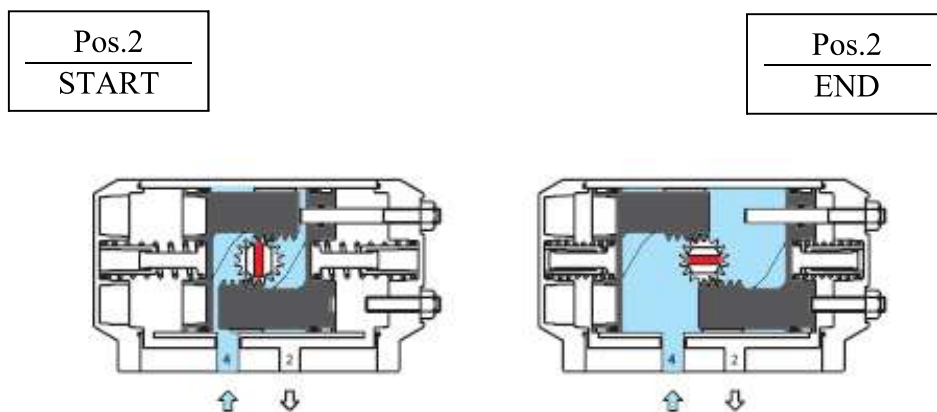

Entrada aire # 4 = Pistón Abre

-----  
Air in # 4 = Pistons Open

## Fase de Cierre – Closing Phase

Pos.1  
START

Pos.1  
END

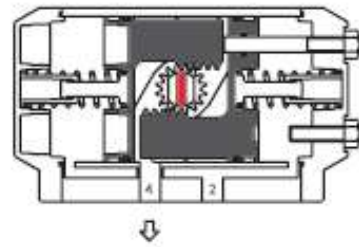
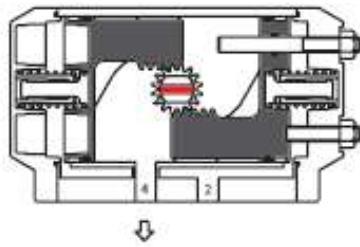

Sin aire = Pistón Cierra (mediante los muelles)

Without Air = Pistons Closed (Spring Release)



### DIMENSIONES

### DIMENSIONS

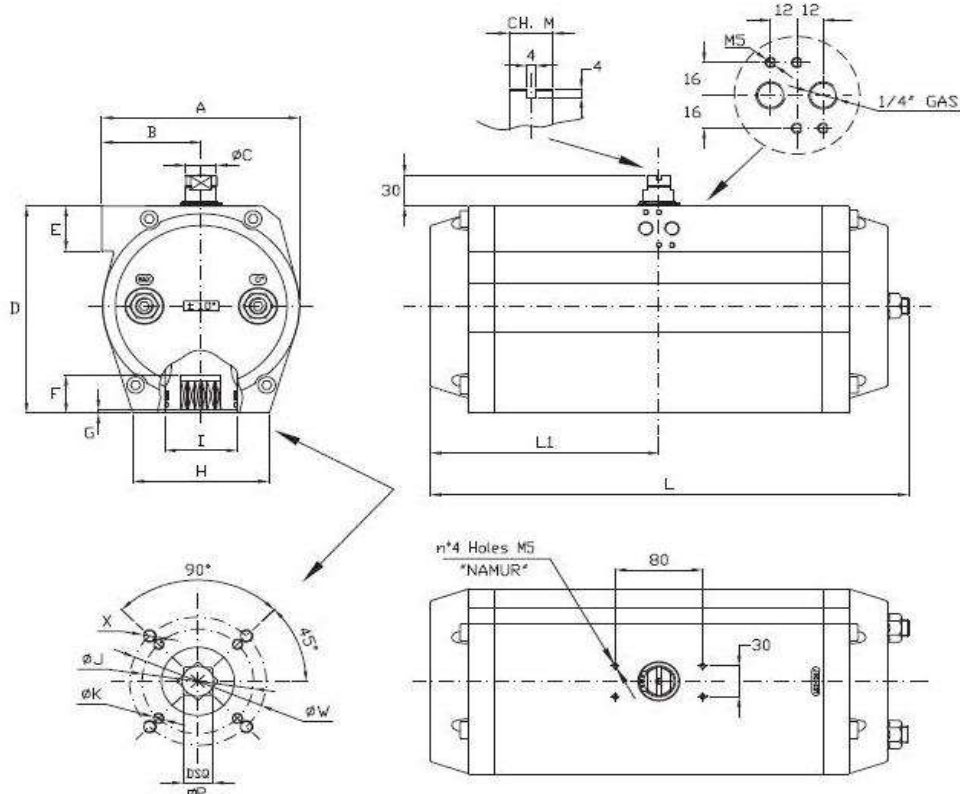

Modelos / Models	Dimensiones / Dimensions (mm)											
	DSQ	ISO 5211	A	B	D	E	F	G	H	Ø I	L	L1
GN 05	11	F03 / F05	67	40	71	45	12.5	1.5	47	22	119	59.5
GN 15	14	F05 / F07	81	47	81	45	19	2	62	33	175	82.5
GN 17	14	F05 / F07	81	47	81	45	19	2	62	33	207	98.5
GN 20	17	F05 / F07	96	54	98	45	19	2	76.5	35	186	88.5
GN 25	17	F05 / F07	96	54	98	45	23	2	76.5	40.5	248	119.5
GN 30	17	F05 / F07	114	62	117	45	23	2	90.5	40.5	241	115
GN 35	22	F07 / F10	131	66	154	45	30	3	95.5	40.5	261	123
GN 40	22	F07 / F10	131	66	154	45	30	3	95.5	45	305	145
GN 45	22	F07 / F10	145	73	168	45	30	3	98.5	56.5	367	175.5
GN 50	27	F10 / F12	181	91	202	45	31	3	124.5	54.5	380	180.5
GN 55	27	F10 / F12	181	91	202	45	37	3	124.5	66.5	428	209
GN 60	36	F12 o F14	230	114	257	45	41	4	160.5	70	467	210
GN 65	36	F12 o F14	230	114	257	45	50	4	160.5	80	525	251
GN 70	46	F16	338	169	328	55	64	5	155	105	636	305.5
GN 75	46	F16	338	169	328	55	64	5	155	140	734	354

## Ajuste del Recorrido / Travel adjustment

Tiene un rango de ajuste de  $\pm 10^\circ$  para la rotación en  $90^\circ$  / Have adjustment range of  $\pm 10^\circ$  for the rotation at  $90^\circ$

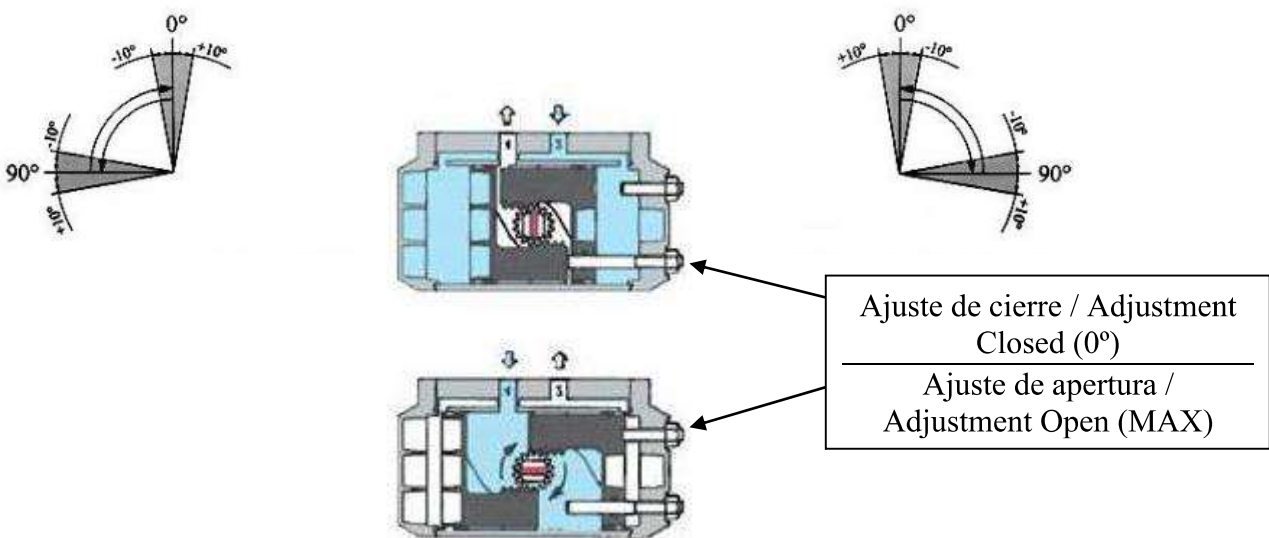

## CONSUMO DE AIRE (Ciclo Completo)

## AIR CONSUMPTION (Full Cycle)

Model	Doble Efecto Double Acting	Simple Efecto Spring Return
GN 05	0.22	0.13
GN 15	0.41	0.18
GN 17	0.55	0.25
GN 20	0.71	0.29
GN 25	1.10	0.48
GN 30	1.40	0.65
GN 35	2.45	1.20
GN 40	3.05	1.60
GN 45	4.40	1.85
GN 50	6.80	2.90
GN 55	9.00	4.10
GN 60	14.10	5.50
GN 65	16.60	7.10
GN 70	27.10	9.60
GN 75	31.40	11.70

Consumo en N. Lt. / Consumption in N. Lt. (N=Normal Presion Atmosférica / Atmospheric Pressure)

## PESO ( Kg)

## WEIGHT (Kg)

Modelo / Type	GN 05	GN 15	GN 17	GN 20	GN 25	GN 30	GN 35	GN 40	GN 45	GN 50	GN 55	GN 60	GN 65	GN 70	GN 75
SE / SR	0.99	1.69	2.42	2.53	3.77	4.88	7.89	9.38	13.21	22.60	27	45.9	52.40	82.96	98
DE / DA	0.91	1.50	2.18	2.15	3.25	4.15	6.45	7.70	10.65	17.80	22.18	36.30	42.80	66.80	81.60

## DIMENSIONADO DOBLE EFECTO

El factor de seguridad sugerido para los actuadores de Doble Efecto bajo condiciones de trabajo normales es del 20% al 35%.

Ejemplo:

- El Par necesario para la válvula es de = 100 Nm
- El Par considerando el factor de seguridad (100 + 30%) es de 130 Nm
- Presión del aire de alimentación = 6 bar

De acuerdo con la Tabla de Pares, nosotros debemos elegir el modelo más aproximado que es el **GN - 35 (193,3 Nm)**

## DOUBLE ACTING SIZING

The suggested safety factor for Double Acting actuators under normal working conditions is 20%-35%.

Example:

- The torque needed by valve=100Nm
- The torque considered safety factor (100 + 30%) = 130Nm
- Air Suplí = 6 bar

According to the above Torque Table, we can choose the minimum model is: **GN- 35 (193,3 Nm)**

## DIMENSIONADO SIMPLE EFECTO

El factor de seguridad sugerido para los actuadores de Simple Efecto bajo condiciones de trabajo normales es del 20% al 35%.

Ejemplo:

- El Par necesario para la válvula = 100 Nm
- El Par considerando el factor de seguridad (100 + 20%) es de 120 Nm
- Presión del aire de alimentación = 6 bar

De acuerdo con la Tabla de Pares que nos dan los actuadores de Simple Efecto, encontramos que los valores de pares del modelo **GN 45 S4 (4+4)** son:

Ejercido por aire a 0° = 251,2 Nm  
Ejercido por aire a 90° = 176,6 Nm  
Ejercido por muelles a 90° = 200,8 Nm  
Ejercido por muelles a 0° = 126,2 Nm

Todos los pares obtenidos son superiores al necesitado por la válvula

## SPRING RETURN SIZING

*The suggested safety factor for spring return actuator under normal working conditions is 30-50%*

*Example:*

- *The torque needed by valve = 100 Nm*
- *The torque consider safety factor*
- *(100 + 20%) = 120 Nm*
- *Air Supply = 6 bar*

*According to the table of spring return actuators' output, we find output torque of **GN 45 S4 (4+4)** are:*

*Air stroke 0° = 251,2 Nm  
Air stroke 90° = 176,6 Nm  
Spring stroke 90° = 200,8 Nm  
Spring stroke 0° = 126,2 Nm*

*All the output torque is larger than we needed.*

## PARES ACTUADORES SIMPLE EFECTO (Nm) / SPRING RETURN ACTUATORS TORQUES (Nm)

### Colocación de Muelles en Pistón derecho / Spring Assembly Right Piston



### Colocación de Muelles en Pistón Izquierdo / Spring Assembly Left Piston



TIPO / TYPE	Cantidad de muelles / Spring Qty	PRESIÓN DE AIRE DE ENTRADA EN BAR / AIR SUPPLY IN BAR														Obtenido por muelle / Spring output	
		3		4		5		5.62		6		7		8		90°	0°
		0°	90°	0°	90°	0°	90°	0°	90°	0°	90°	0°	90°	0°	90°		
GN-05S	1 + 1	5.1	3.9	7.6	6.4	10.1	8.9	11.6	10.4	12.6	11.4	15.1	13.9	17.7	16.5	3.7	2.5
	2 + 2	2.6	0.2	5.1	2.7	7.6	5.2	9.1	6.7	10.1	7.7	12.6	10.2	15.2	12.8	7.4	5.0
	3 + 3	--	--	--	--	5.1	1.5	6.6	3.0	7.6	4.0	10.1	6.5	12.7	9.1	11.2	7.5
GN-15S	2 + 2	10.5	8.1	16.0	13.6	21.5	19.1	24.6	22.5	27.0	24.6	32.5	30.1	38.0	35.6	8.4	6.0
	3 + 3	7.4	3.9	12.9	9.4	18.4	14.9	21.8	18.3	23.9	20.4	29.4	25.9	34.9	31.4	12.6	9.1
	4 + 4	--	--	9.9	5.1	15.4	10.6	18.8	14.0	20.9	16.1	26.4	21.6	31.9	27.1	16.9	12.1
	5 + 5	--	--	6.9	0.9	12.4	6.4	15.8	9.8	17.9	11.9	23.4	17.4	28.9	22.9	21.1	15.1
	7 + 5	--	--	--	--	9.4	2.2	12.8	5.6	14.9	7.7	20.4	13.2	25.9	18.7	25.3	18.1
GN-17S	2 + 2	14.5	11.2	21.8	18.5	29.0	25.7	33.4	30.1	36.3	33.0	43.5	40.2	50.8	47.5	10.5	7.2
	3 + 3	10.9	6.0	18.2	13.3	25.4	20.5	29.8	24.9	32.7	27.8	39.9	35.0	47.2	42.3	15.7	10.8
	4 + 4	7.3	0.8	14.6	8.1	21.8	15.3	26.2	19.7	29.1	22.6	36.3	29.8	43.6	37.1	20.9	14.4
	5 + 5	--	--	10.9	2.9	18.1	10.1	22.5	14.5	25.4	17.4	32.6	24.6	39.9	31.9	26.1	18.1
	7 + 5	--	--	--	--	14.5	4.8	18.9	9.2	21.8	12.1	29.0	19.3	36.3	26.6	31.4	21.7
GN-20S	2 + 2	19.6	16.2	29.6	26.2	39.6	36.2	46.1	42.7	49.6	46.2	59.6	56.2	69.6	66.2	13.8	10.4
	3 + 3	14.4	9.2	24.4	19.2	34.4	29.2	40.9	35.7	44.4	39.2	54.4	49.2	64.4	59.2	20.8	15.6
	4 + 4	9.2	2.3	19.2	12.3	29.2	22.3	35.7	28.8	39.2	32.3	49.2	42.3	59.2	52.3	27.7	20.8
	5 + 5	--	--	14.0	5.4	24.0	15.4	30.5	21.9	34.0	25.4	44.0	35.4	54.0	45.4	34.6	26.0
	7 + 5	--	--	--	--	18.8	8.4	25.3	14.9	28.8	18.4	38.8	28.4	48.8	38.4	41.6	31.2
GN-25S	2 + 2	31.3	23.2	46.4	38.3	61.5	53.4	70.5	62.4	76.6	68.5	91.7	83.6	106.8	98.7	22.1	14.0
	3 + 3	24.4	12.1	39.5	27.2	54.6	42.3	63.6	51.3	69.7	57.4	84.8	72.5	99.9	87.6	33.2	20.9
	4 + 4	17.4	1.1	32.5	16.2	47.6	31.3	56.6	40.3	62.7	46.4	77.8	61.5	92.9	76.6	44.2	27.9
	5 + 5	--	--	25.5	5.1	40.6	20.2	49.6	29.2	55.7	35.3	70.8	50.4	85.9	65.5	55.3	34.9
	7 + 5	--	--	--	--	33.6	9.2	42.6	18.2	48.7	24.3	63.8	39.4	78.9	54.5	66.3	41.9
GN-30S	2 + 2	39.2	32.0	59.3	52.1	79.4	72.2	91.6	84.4	99.5	92.3	119.6	112.4	139.7	132.5	28.3	21.1
	3 + 3	28.7	17.9	48.8	38.0	68.9	58.1	81.1	70.3	89.0	78.2	109.1	98.3	129.2	118.4	42.4	31.6
	4 + 4	18.1	3.7	38.2	23.8	58.3	43.9	70.5	56.1	78.4	64.0	98.5	84.1	118.6	104.2	56.6	42.2
	5 + 5	--	--	27.7	9.7	47.8	29.8	60.0	42.0	67.9	49.9	88.0	70.0	108.1	90.1	70.7	52.7
	7 + 5	--	--	--	--	37.3	15.6	49.5	27.8	57.4	35.7	77.5	55.8	97.6	75.9	84.9	63.2
GN-35S	2 + 2	62.0	50.1	94.2	82.3	126.5	114.6	145.8	133.9	158.7	146.8	190.9	179.0	223.1	211.2	46.5	34.6
	3 + 3	44.6	26.9	76.8	59.1	109.1	91.4	128.4	110.7	141.3	123.6	173.5	155.8	205.7	188.0	69.7	52.0
	4 + 4	27.2	3.6	59.5	35.8	91.8	68.1	111.1	87.4	124.0	100.3	156.2	132.5	188.4	164.7	93.0	69.3
	5 + 5	--	--	42.2	12.6	74.5	44.9	93.8	64.2	106.7	77.1	138.9	109.3	171.1	141.4	116.2	86.6
	7 + 5	--	--	--	--	57.1	21.6	76.4	40.9	89.3	53.8	121.5	86.0	153.7	118.2	139.5	104.0
GN-40S	2 + 2	79.0	63.9	119.3	104.2	159.6	144.5	183.8	168.7	199.9	184.8	240.3	225.2	280.6	265.5	57.0	41.9
	3 + 3	58.1	35.4	98.4	75.7	138.7	116.0	162.9	140.2	179.0	156.3	219.4	196.7	259.7	237.0	85.5	62.8
	4 + 4	37.2	6.8	77.5	47.1	117.8	87.4	142.0	111.6	158.1	127.7	198.5	168.1	238.8	208.4	114.1	83.7
	5 + 5	--	--	56.5	18.6	96.8	58.9	121.0	83.1	137.1	99.2	177.5	139.6	217.8	179.9	142.6	104.7
	7 + 5	--	--	--	--	75.9	30.4	100.1	54.6	116.2	70.7	156.6	111.1	196.9	151.4	171.1	125.6
GN-45S	2 + 2	125.6	88.3	188.5	151.2	251.4	214.1	289.6	252.3	314.3	277.0	377.2	339.9	440.1	402.8	100.4	63.1
	3 + 3	94.0	38.1	156.9	101.0	219.8	163.9	258.0	202.1	282.7	226.8	345.6	289.7	408.5	352.6	150.6	94.7
	4 + 4	--	--	125.4	50.8	188.3	113.7	226.5	151.9	251.2	176.6	314.1	239.5	377.0	302.4	200.8	126.2
	5 + 5	--	--	--	--	156.7	63.5	194.9	101.7	219.6	126.4	282.5	189.3	345.4	252.2	251.0	157.8
	7 + 5	--	--	--	--	125.2	13.3	163.4	51.5	188.1	76.2	251.0	139.1	313.9	202.0	301.2	189.3
GN-50S	2 + 2	173.7	147.5	264.3	238.1	354.9	328.7	411.1	384.9	445.5	419.3	536.1	509.9	626.7	600.5	124.3	98.1
	3 + 3	124.6	85.3	215.2	175.9	305.8	266.5	362.0	322.7	396.4	357.1	487.0	447.7	577.6	538.2	186.5	147.2
	4 + 4	--	--	166.2	113.8	256.8	204.4	313.0	260.6	347.4	295.0	438.0	385.6	528.6	476.2	248.6	196.2
	5 + 5	--	--	117.1	51.6	207.7	142.2	263.9	198.4	298.3	232.8	388.9	323.4	479.5	414.0	310.8	245.3
	7 + 5	--	--	--	--	158.7	80.1	214.9	136.3	249.3	170.7	339.9	261.3	430.5	351.9	372.9	294.3
GN-55S	2 + 2	243.2	194.4	364.0	315.2	484.8	436	557.3	508.5	605.6	556.8	726.4	677.6	847.2	798.4	167.9	119.1
	3 + 3	183.6	110.5	304.0	213.3	425.2	352.1	497.7	424.6	546.0	472.9	666.8	593.7	787.6	714.5	251.8	178.7
	4 + 4	124	26.6	244.8	147.4	365.6	268.2	438.1	340.7	486.4	389.0	607.2	509.8	728.0	630.6	335.7	238.3
	5 + 5	--	--	185.3	63.4	306.1	184.2	378.6	256.7	426.8	305.0	547.7	425.8	668.5	546.6	419.7	297.8
	7 + 5	--	--	--	--	246.5	100.3	319.0	172.8	367.3	221.1	488.1	341.9	608.9	462.7	503.6	357.4
GN-60S	2 + 2	356.5	307.4	539.7	490.6	722.9	673.8	836.5	787.4	906.1	857.0	1089.3	1040.2	1272.5	1223.4	242.2	193.1
	3 + 3	260.0	186.2	443.2	369.4	626.4	552.6	740.0	666.2	812.6	735.8	992.8	919.0	1176.0	1102.2	363.4	289.6
	4 + 4	163.4	65.1	346.6	248.3	529.8	431.5	643.4	545.1	713.0	614.7	896.2	797.9	1079.4	981.1	484.5	386.2
	5 + 5	--	--	250.1	127.2	433.3	310.4	546.9	424.0	616.5	493.6	799.7	676.8	982.9	860.0	605.6	482.7
	7 + 5	--	--	153.5	6.2	336.7	189.4	450.3	303.0	519.9	372.6	703.1	555.8	886.3	739.0	726.6	579.3
GN-65S	2 + 2	489.6	404.7	731.8	649.3	972.8	890.9	1122.6	1040.7	1214.4	1132.5	1456.6	1374.1	1697.6	1615.5	317.1	235.2
	3 + 3	372.0	249.1	613.6	490.7	855.2	732.3	1005.0	882.1	1096.8	973.9	1338.4	1215.5	1580.0	1457.1	475.7	352.8
	4 + 4	254.3	90.6	495.9	332.2	737.5	573.8	887.3	723.6	979.1	815.4	1220.7	1057.0	1462.3	1298.6	634.2	470.5
	5 + 5	--	--	378.3	173.6	619.9	415.2	769.7	565.0	861.5	656.8	1103.1	898.4	1344.7	1140.0	792.8	588.1
	7 + 5	--	--	260.8	14.8	502.4	256.4	652.2	406.2	744.0	498.0	985.6	739.6	1227.2	981.2	951.6	705.6

TIPO / TYPE	Cantidad de muelles / Spring Qty	PRESIÓN DE AIRE DE ENTRADA EN BAR / AIR SUPPLY IN BAR														Obtenido por muelle / Spring output	
		3		4		5		5.62		6		7		8		90°	0°
		0°	90°	0°	90°	0°	90°	0°	90°	0°	90°	0°	90°	0°	90°		
GN-70S	2 + 2	1073.0	940.0	1546.0	1413.0	2019.0	1886.0	2312.0	2179.0	2492.0	2359.0	2965.0	2832.0	3438.0	3305.0	479.0	346.0
	3 + 3	900.0	700.0	1373.0	1173.0	1846.0	1646.0	2139.0	1939.0	2319.0	2119.0	2792.0	2592.0	3265.0	3065.0	719.0	519.0
	4 + 4	727.0	461.0	1200.0	934.0	1673.0	1407.0	1966.0	1700.0	2146.0	1880.0	2619.0	2353.0	3092.0	2826.0	958.0	692.0
	5 + 5	--	--	1026.0	694.0	1499.0	1167.0	1792.0	1460.0	1972.0	1640.0	2445.0	2113.0	2918.0	2586.0	1198.0	866.0
	6 + 6	--	--	853.0	454.0	1326.0	927.0	1619.0	1220.0	1799.0	1400.0	2272.0	1873.0	2745.0	2346.0	1438.0	1039.0
	7 + 7	--	--	--	--	1153.0	688.0	1446.0	981.0	1626.0	1161.0	2099.0	1634.0	2572.0	2107.0	1677.0	1212.0
	8 + 8	--	--	--	--	--	--	1273.0	741.0	1453.0	921.0	1926.0	1394.0	2399.0	1867.0	1917.0	1385.0
	GN-75S	2 + 2	1500.0	1261.0	2134.0	1895.0	2768.0	2529.0	3161.0	2922.0	3402.0	3163.0	4036.0	3797.0	4671.0	4432.0	642.0
3 + 3		1299.0	940.0	1933.0	1574.0	2567.0	2208.0	2960.0	2601.0	3201.0	2842.0	3835.0	3476.0	4470.0	4111.0	963.0	604.0
4 + 4		1098.0	619.0	1732.0	1253.0	2366.0	1887.0	2759.0	2280.0	3000.0	2521.0	3634.0	3155.0	4269.0	3790.0	1284.0	805.0
5 + 5		--	--	1530.0	933.0	2164.0	1567.0	2557.0	1960.0	2798.0	2201.0	3432.0	2835.0	4067.0	3470.0	1604.0	1007.0
6 + 6		--	--	1329.0	612.0	1963.0	1246.0	2356.0	1639.0	2597.0	1880.0	3231.0	2514.0	3866.0	3149.0	1925.0	1208.0
7 + 7		--	--	--	--	1761.0	925.0	2154.0	1318.0	2395.0	1559.0	3029.0	2193.0	3664.0	2828.0	2246.0	1410.0
8 + 8		--	--	--	--	1560.0	604.0	1953.0	997.0	2194.0	1238.0	2828.0	1872.0	3463.0	2507.0	2567.0	1611.0

## PARES ACTUADORES DOBLE EFECTO (Nm) / DOUBLE ACTING ACTUATORS TORQUES (Nm)

Modelo / Model	Presión alimentación de aire (Bar) / Air supply pressure (Unit Bar)									
	2	3	4	5	5.62	6	7	8	9	10
GN 05	5.0	7.6	10.1	12.6	14.1	15.1	17.6	20.2	22.7	25.2
GN 15	11.0	16.5	22.0	27.5	30.9	33.0	38.5	44.0	49.5	55.0
GN 17	14.5	21.7	29.0	36.2	40.6	43.5	50.7	58.0	65.2	72.5
GN 20	20.0	30.0	40.0	50.0	56.5	60.0	70.0	80.0	90.0	100.0
GN 25	30.2	45.3	60.4	75.5	84.5	90.6	105.7	120.8	135.9	151.0
GN 30	40.0	60.3	80.4	100.5	112.7	120.6	140.7	160.8	180.9	201.0
GN 35	64.4	96.6	128.8	161.1	180.4	193.3	225.5	257.7	289.9	322.1
GN 40	80.6	120.9	161.2	201.5	225.7	241.8	282.2	322.5	362.8	403.1
GN 45	125.8	188.7	251.6	314.5	352.7	377.4	440.3	503.2	566.1	629.0
GN 50	181.2	271.8	362.4	453.0	509.2	543.6	634.2	724.8	815.4	906.0
GN 55	241.6	362.3	483.1	603.9	676.4	724.7	845.5	966.3	1087.1	1207.8
GN 60	366.4	549.6	732.8	916.0	1029.6	1099.2	1282.4	1465.6	1648.8	1832.0
GN 65	483.2	724.8	966.4	1208.0	1357.8	1449.6	1691.2	1932.8	2174.4	2416.0
GN 70	946.0	1419.0	1892.0	2635.0	2658.0	2838.0	3311.0	3784.0	***	***
GN 75	1268.0	1903.0	2537.0	3171.0	3564.0	3805.0	4439.0	5074.0	***	***