

## ARTICULO: 2416

### Válvula de retención a disco, extremos roscados Single disk check valve, threaded ends

#### Características

1. Válvula de retención a disco.
2. Extremos roscados según ISO 7-1 (EN 10226-1).
3. Construcción en Acero Inox. 1.4408 (CF8M).
4. Disco en Acero Inox. 1.4408 (CF8M).
5. Resorte en Acero Inox. AISI 316.
6. Dimensiones reducidas.
7. Cierre metal – metal.
8. Presión de trabajo máxima 63 bar.
9. Temperatura de trabajo -20°C +240°C.

#### Features

1. Single disk check valve.
2. Threaded ends acc. to ISO 7-1 (EN 10226-1).
3. Made of Stainless Steel 1.4408 (CF8M).
4. Disk made of Stainless Steel 1.4408 (CF8M).
5. Spring made of Stainless Steel AISI 316.
6. Small dimensions.
7. Metal to metal sealing.
8. Max. working pressure 63 bar.
9. Working Temperature -20°C +240°C.

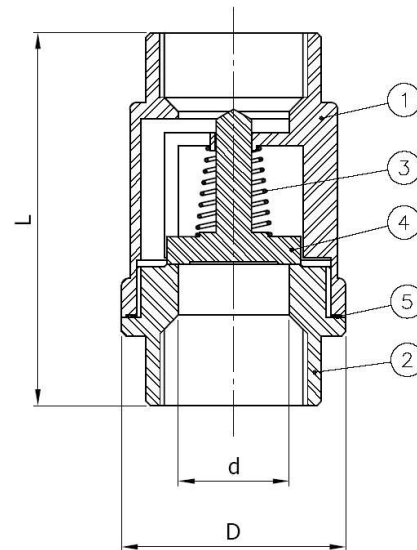

Nº	Denominación / Name	Material	Acabado Superficial / Surface Treatment
1	Cuerpo / Body	Acero Inox. / Stainless Steel 1.4408	Granallado / Shot blasting
2	Tapa / Cap	Acero Inox. / Stainless Steel 1.4408	Granallado / Shot blasting
3	Muelle / Spring	Acero Inox. / Stainless Steel AISI 316	-----
4	Disco / Disk	Acero Inox. / Stainless Steel 1.4408	Granallado / Shot blasting
5	Junta / Gasket	PTFE	-----

## DIMENSIONES GENERALES / GENERAL DIMENSIONS:

Ref.	Medida/Size	DN	PN	Dimensiones/Dimensions (mm)			Opening Pressure ↑ (mbar)	Peso/Weight (Kg)
				d	D	L		
2416 02	1/4"	8	63	8	30,5	53	80~90	0,170
2416 03	3/8"	10	63	10	30,5	53	60~70	0,160
2416 04	1/2"	15	63	15	37	56	55~65	0,210
2416 05	3/4"	20	63	20	42	63	50~60	0,290
2416 06	1"	25	63	25	48	74	45~50	0,410
2416 07	1 1/4"	32	63	30	58	81	35~40	0,660
2416 08	1 1/2"	40	63	38	70	91	25~30	0,990
2416 09	2 "	50	63	47	82	97	25~30	1,420
2416 10	2 1/2"	65	63	61	102,5	118	25~30	2,440
2416 11	3"	80	63	75	120	138	20~25	3,800
2416 12	4"	100	63	94	150	158	20~25	6,600

## CURVA PRESIÓ N TEMPERATURA / PRESSURE TEMPERATURE RATING

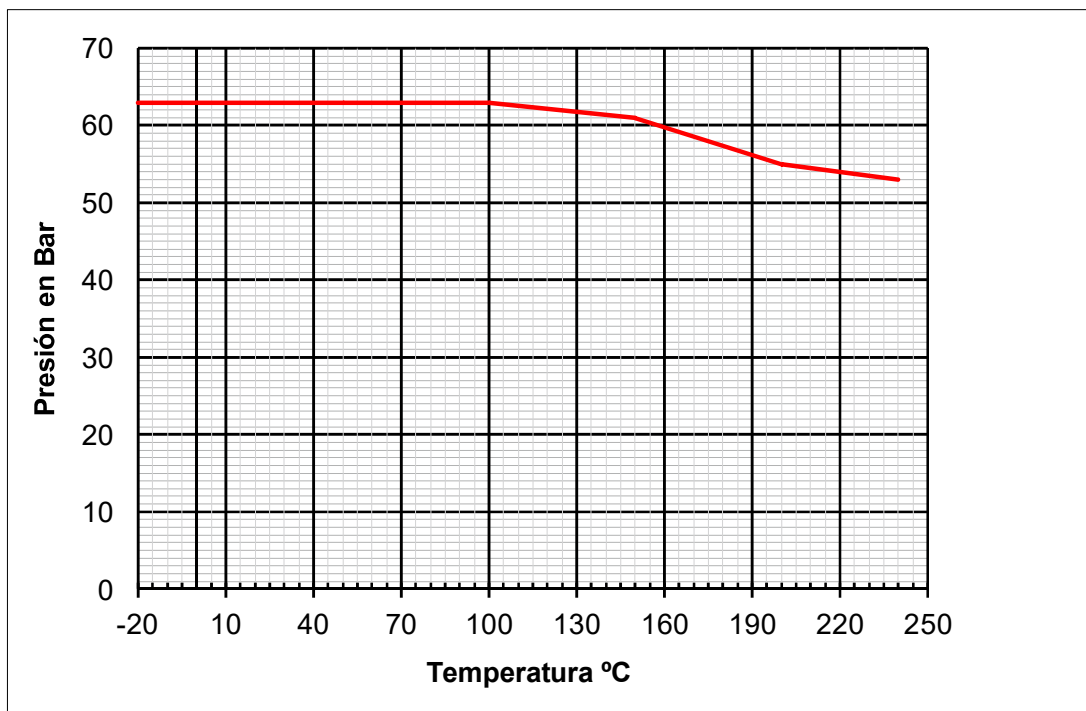

## VALORES DE Kv / Kv VALUES

Kv = Es la cantidad de metros cúbicos por hora (m<sup>3</sup>/h) que pasará a través de la válvula generando una pérdida de carga de 1 bar.

*Kv = Flow rate of water in cubic meter per hour (m<sup>3</sup>/h) that will generate a pressure drop of 1 bar across the valve.*

1/4"	3/8"	1/2"	3/4"	1"	1 1/4"	1 1/2"	2"	2 1/2"	3"	4"
0,18	1,11	3,3	7,1	12,7	14,1	22,5	31,5	54	75	110

