

## ARTICULO: 2104

### Válvula de mariposa tipo wafer. Acero Inoxidable + PTFE Butterfly valve wafer type. Stainless Steel + PTFE

Características	Features
1. Válvula de mariposa tipo wafer. 2. Cuerpo bipartido de Acero Inoxidable 1.4408 (CF8M) para montaje entre bridas ANSI 150 y EN 1092 PN 10/16. 3. Asiento de PTFE con base de EPDM 4. Disco de Acero Inoxidable 1.4408 (CF8M). 5. Eje Acero Inoxidable AISI 316. 6. Brida montaje actuadores según ISO 5211. 7. Longitud entre caras según EN 558-1 Serie 20 (DIN 3202 K1). 8. Máxima presión de trabajo 10 bar. 9. Temperatura de trabajo $-25^{\circ}\text{C} + 180^{\circ}\text{C}$ .	1. Butterfly valve wafer type. 2. Stainless Steel 1.4408 (CF8M) split body allows installation between ANSI 150 and EN 1092 PN 10/16 pipe flanges. 3. PTFE body seat on EPDM backseat. 4. Butterfly disc made of Stainless Steel 1.4408 (CF8M). 5. Stem made of Stainless Steel AISI 316. 6. Actuator mounting plate according to ISO 5211. 7. Face to face according to EN 558-1 Series 20 (DIN 3202 K1). 8. Max. working pressure 10 bar. 9. Working Temperature $-25^{\circ}\text{C} + 180^{\circ}\text{C}$ .

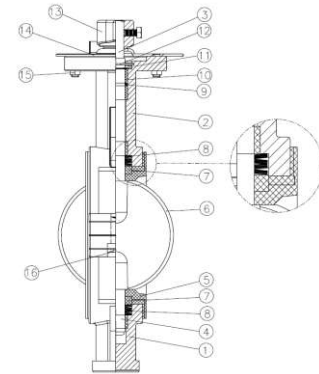

Nº	Denominación / Name	Material	Acabado Superficial / Surface Treatment	Cód. Recambio Spare Part Code
1	Cuerpo Inferior / Downside Body	Acero Inox. / Stainless Steel 1.4408	Granallado / Shot Blasting	-----
2	Cuerpo Superior / Upside Body	Acero Inox. / Stainless Steel 1.4408	Granallado / Shot Blasting	-----
3	Eje Superior / Upside Stem	Acero Inox. / Stainless Steel AISI 316	-----	-----
4	Eje Inferior / Downside Stem	Acero Inox. / Stainless Steel AISI 316	-----	-----
5 *	Asiento / Seat	PTFE c/base EPDM / PTFE on EPDM	-----	ET2104
6	Disco / Disc	Acero Inox. / Stainless Steel 1.4408	Granallado / Shot Blasting	-----
7	Buje / Hub	RPTFE	-----	-----
8	Arandelas Muelle / Spring washer	Acero Inox. / Stainless Steel AISI 301	-----	-----
9	Tórica / O'ring	Viton	-----	-----
10	Casquillo / Bush	RPTFE	-----	-----
11	Arandela / Washer	Acero Inox. / Stainless Steel AISI 304	-----	-----
12	Arandela Seeger / Seeger ring	Acero Inox. / Stainless Steel AISI 304	-----	-----
13	Maneta / Handle	Acero Inox. / Stainless Steel AISI 304	Pulido / Polished	-----
14	Plato / Plate	Acero Inox. / Stainless Steel AISI 304	Pulido / Polished	-----
15	Tornillo-Tuerca / Screw-Nut	Acero Inox. / Stainless Steel AISI 304	-----	-----
16	Tornillo / Screw	Acero Inox. / Stainless Steel AISI 304	-----	-----

\* Piezas de recambio disponibles / Available spare parts

## DIMENSIONES GENERALES / GENERAL DIMENSIONS:

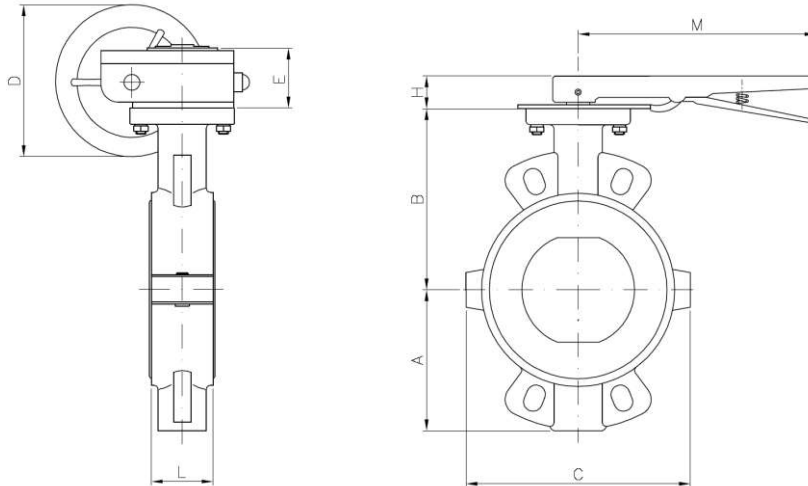

Ref	Medida / Size	DN	PN	Dimensiones / Dimensions (mm)								Peso / Weight (Kg)
				L	A	B	C	D	E	H	M	
2104 09	2"	50	10	43	74	136	117	***	***	32	264	2,700
2104 10	2 1/2"	65	10	46	82	138	126	***	***	32	264	3,300
2104 11	3"	80	10	46	90	138	142	***	***	32	264	3,600
2104 12	4"	100	10	52	116	158	178	***	***	32	264	5,400
2104 13	5"	125	10	56	132	174	202	***	***	32	264	7,400
2104 14	6"	150	10	56	145	190	234	200	55	***	***	10,500
2104 16	8"	200	10	60	180	229	286	220	71	***	***	18,100
2104 18	10"	250	10	68	210	264	338	300	71	***	***	24,900

\*\*\* Nota: A partir de 6" ( DN 150 ), operación mediante reductor manual.

\*\*\* Note: From 6" ( DN 150 ), handling by gear operator.

## Dimensiones de brida superior / Top flange dimensions:

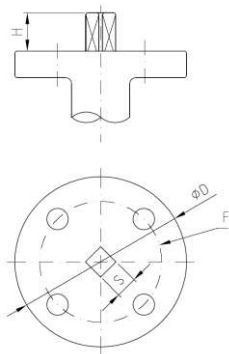

Dimensiones brida Superior / Top flange dimensions					
Ref.	F (ISO5211)	S	D	H	Torque Nm.
2104 09	F05	11	65	32	20
2104 10	F05	11	65	32	25
2104 11	F05	11	65	32	30
2104 12	F07	14	90	32	60
2104 13	F07	14	90	32	100
2104 14	F07	14	90	32	180
2104 16	F10	17	125	45	300
2104 18	F10	22	125	45	400

**Perdidas de Carga ( Kv ) según posición del disco / Head losses (Kv) according to disc position:**

DN	Posición del Disco ( grados ) / Disc Position ( degrees )								
	90°	80°	70°	60°	50°	40°	30°	20°	10°
50	125	99	73	53	37	23	14	6	1
65	244	193	141	93	58	37	21	10	1
80	399	315	231	133	83	53	30	13	2
100	727	606	429	237	148	94	54	23	3
125	1190	991	670	370	232	147	85	37	4
150	1600	1334	887	490	306	195	112	48	5
200	2868	2458	1610	935	588	364	208	88	10
250	4713	3927	2558	1484	933	578	331	140	16

**VALORES DE Kv / Kv VALUES**

$K_v$  (m<sup>3</sup>/h) = Es la cantidad de metros cúbicos por hora que pasará a través de la válvula generando una pérdida de carga de 1 bar.

$K_v$  (m<sup>3</sup>/h) = The rate of flow of water in cubic meter per hour that will generate a pressure drop of 1 bar across the valve

**CURVA PRESIÓN TEMPERATURA / PRESSURE TEMPERATURE RATING**

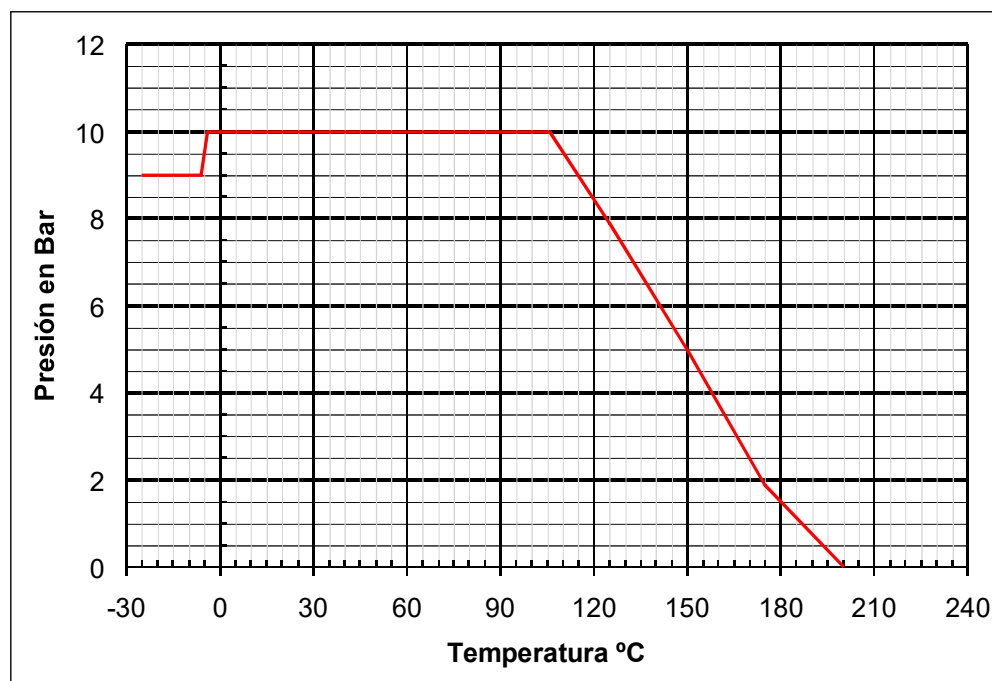

## **Medidas de Precaución para instalación / Caution measures for Installation:**

1. No instale la válvula en posición totalmente cerrada / *Do not assemble the butterfly valve in total closed position.*
2. Verifique el buen paralelismo de las bridas / *Check the good parallelism of the flanges.*
3. No coloque otras juntas entre las bridas / *Do not insert others gasket between flange and valve.*
4. Abra totalmente la válvula antes de apretar las bridas / *Open completely the valve before tightening flanges.*

