

ARTICULO: 2053

Válvula de esfera paso total para Fondo de Cubas

Tank Bottom full port ball valve

Características

1. Válvula esfera paso total 3 piezas
2. Extremos: Fondo de tanque / Butt Weld ANSI B 16.25.
3. Construcción en Acero Inox 1.4408 (CF8M) y 316 L.
4. Asientos PTFE + 15 % Fibra de Vidrio.
5. Tórica en el eje de FPM.
6. Juntas del eje PTFE + 15 % Grafito.
7. Sistema de bloqueo.
8. Montaje actuador directo s/ ISO 5211.
9. Eje inexpulsable.
10. Presión de trabajo máxima 63 bar.
11. Temperatura de trabajo -25 °C + 180 °C.

Features

1. Stainless steel full port ball valve, 3 pieces.
2. Ends: Tank bottom / Butt Weld ANSI B 16.25.
3. Made of stainless steel 1.4408 (CF8M) and 316 L.
4. Ball seats PTFE + 15 % G.F.
5. FPM o'ring stem.
6. Stem gasket PTFE + 15 % Graphite.
7. Locking system.
8. Direct mounting actuator ISO 5211.
9. Blow-out proof stem.
10. Max.. Working pressure 63 bar.
11. Working Temperature -25 °C + 180 °C.

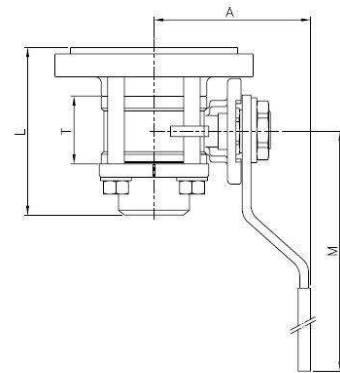
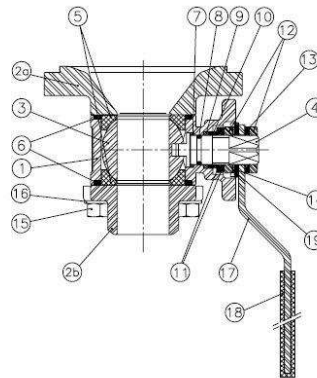

Nº	Denominación / Name	Material	Acabado Superficial / Surface Treatment	Cód. Recambio Spare Part Code
1	Cuerpo / Body	Acero Inox. / Stainless Steel 1.4408	Granallado / Shot blasting	-----
2 a	Brida Fondo de Tanque / Tank Bottom Flange	Acero Inox AISI 316 L / SS 316 L	-----	-----
2 b	Tapa / Cap	Acero Inox. / Stainless Steel 1.4408	Granallado / Shot blasting	-----
3*	Bola / Ball	Acero Inox. / Stainless Steel 1.4408	-----	2907 / 2904 (4")
4*	Eje / Stem	Acero Inox AISI 316 / SS 316	-----	2905
5*	Asiento / Ball Seat	PTFE + 15% F.V. / G.F.	-----	2820
6*	Junta / Gasket	PTFE + grafito / graphite	-----	2820
7*	Arandela / Thrust Washer	PTFE + grafito / graphite	-----	2820
8*	Tórica / O'ring	FPM	-----	2820
9*	Empaquetadura / Stem packing	PTFE	-----	2820
10	Anillo Prensa / Gland	Acero Inox AISI 304 / SS 304	-----	-----
11	Arandela Belleville / Belleville Washer	Acero Inox AISI 301 / SS 301	-----	-----
12	Tuerca / Nut	Acero Inox AISI 304 / SS 304	-----	-----
13	Arandela / Washer	Acero Inox AISI 304 / SS 304	-----	-----

14	Tope / Stopper	Acero Inox AISI 304 / SS 304	-----	-----
15	Tornillo / Bolt	Acero Inox AISI 304 / SS 304	-----	-----
16	Tuerca / Nut	Acero Inox AISI 304 / SS 304	-----	-----
17	Arandela Grover / Grover washer	Acero Inox AISI 304 / SS 304	-----	-----
18	Maneta / Handle	Acero Inox AISI 304 / SS 304	-----	-----
19	Funda / Handle Sleeve	Vinilo / Vynil	-----	-----
20	Antigiro / Lock Washer	Acero Inox AISI 304 / SS 304	-----	-----

*** Piezas que componen los Kit de Reparación / Repair Kit Parts**

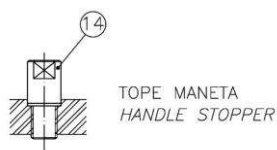

Detalle de la zona de Eje / Stem detail

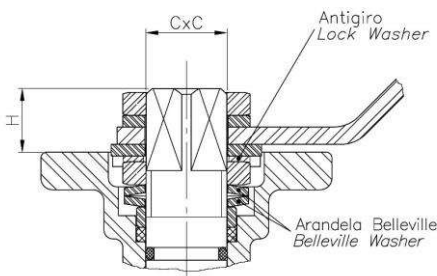

Antigiro / Lock Washer: Previene el desajuste de la tuerca del eje en elevados ciclos de maniobra / Prevents unthreading of stem nut in high cycle automation applications.

Arandela Belleville / Belleville Washer: Las arandelas belleville proporcionan una carga constante sobre el prensa asegurando un cierre firme en variaciones de condiciones de trabajo. / Standard belleville washers provide constant "live load" on the stem seals, assuring a tight seal even varying service parameters.

DIMENSIONES GENERALES / GENERAL DIMENSIONS

Ref	Medida / Size	PN	Paso / Bore	Dimensiones / Dimensions (mm)			
				A	L	M	T
2053 04	1/2"	63	15	60	65.5	112	24
2053 05	3/4"	63	20	70	76.2	138	30
2053 06	1"	63	25	70	83.3	138	33.5
2053 07	1 ¼"	63	32	88	91.3	160	41.5
2053 08	1 ½"	63	40	94	103.3	205	51.5
2053 09	2"	63	50	100	116.5	205	63
2053 10	2 ½"	63	65	150	147.3	325	83.5
2053 11	3"	63	80	165	169	325	100
2053 12	4"	63	100	175	198	325	118.5

Ref	Medida / Size	PN	Dimensiones / Dimensions (mm)		
			H	C x C	ISO 5211
2053 04	1/2"	63	11	9 x 9	F-03/F-04
2053 05	3/4"	63	11	11 x 11	F-04/F-05
2053 06	1"	63	11	11 x 11	F-04/F-05
2053 07	1 1/4"	63	15	14 x 14	F-05/F-07
2053 08	1 1/2"	63	15	14 x 14	F-05/F-07
2053 09	2"	63	15	14 x 14	F-05/F-07
2053 10	2 1/2"	63	19	17 x 17	F-07/F-10
2053 11	3"	63	19	17 x 17	F-07/F-10
2053 12	4"	63	19	17 x 17	F-07/F-10

Extremo Fondo de Tanque y Butt Weld / Tank Bottom Flange and Butt Weld end

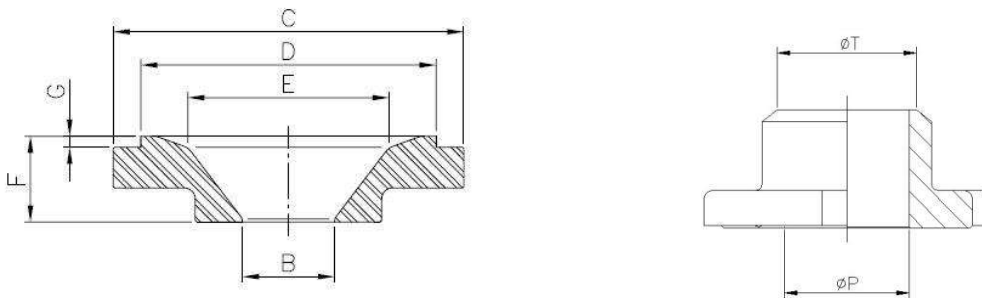

Ref	Medida / Size	Medidas / Dimensions (mm)						
		B / Ø P	C	D	E	F	G	Ø T
2053 04	1/2"	15	70	60	40	25	3	17
2053 05	3/4"	20	85	75	50	25	3	22
2053 06	1"	25	95	80	55	25	3	28
2053 07	1 1/4"	32	110	90	60	25	3	35
2053 08	1 1/2"	40	130	110	74	25	3	43
2053 09	2"	50	150	140	91	25	3	54
2053 10	2 1/2"	65	185	175	108	28	5	69
2053 11	3"	80	200	185	128	28	5	87
2053 12	4"	100	240	220	150	28	5	105

CURVA PRESION TEMPERATURA / PRESSURE TEMPERATURE RATING

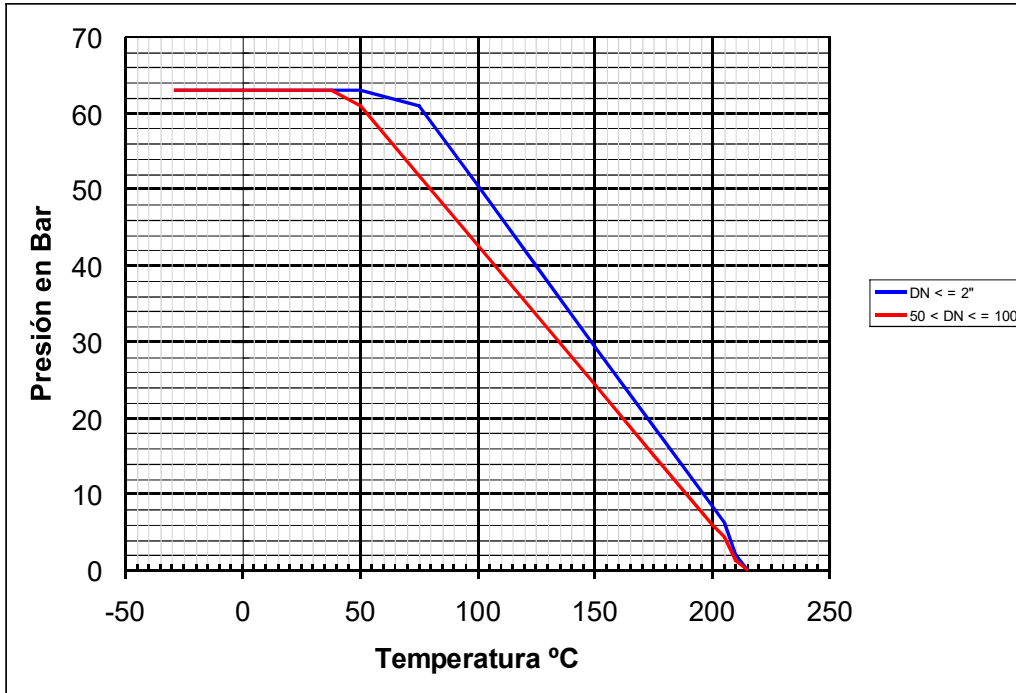

VALORES DE Kv / Kv VALUES

Kv = Es la cantidad de metros cúbicos por hora que pasará a través de la válvula generando una pérdida de carga de 1 bar.

Kv = The rate of flow of water in cubic meter per hour that will generate a pressure drop of 1 bar across the valve.

1/2"	3/4"	1"	1 ¼"	1 ½"	2"	2 ½"	3"	4"
24	43	83	130	205	340	520	1100	1820



PT. LAMINDO PRIMA MANDIRI

Ciputra International Office Tower 3, 12th Floor
 Jl. Lingkar Luar Barat, Block A No. 1 Rawa Buaya, Cengkareng – West Jakarta 11740A